

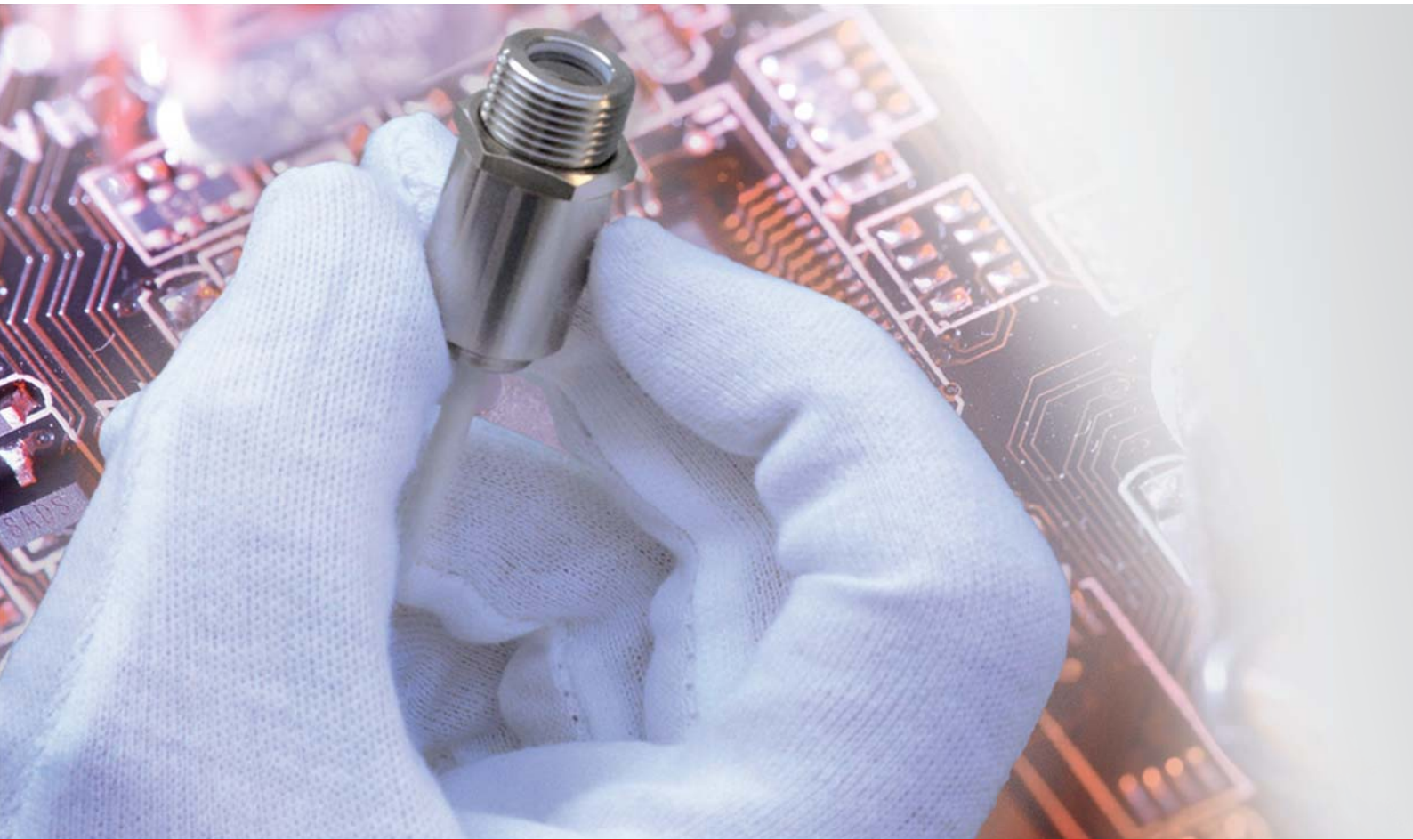

# **Product Overview**

## **For Non-Contact Temperature Measurement**

# Innovative Infrared Technology



## Content

4	Optris GmbH
5-8	How do I find the ideal measurement device?
9-16	Features of the compact series
17-23	Features of the high performance series
24-25	Software for the compact and high performance series
26-28	Electronic box for the compact and high performance series
29-36	Features of the infrared cameras
37-39	Features of the portable thermometers



Spot Measurement With Infrared Thermometers



Interface mA



Interface CAN-Bus



Thermal Imaging With Infrared Cameras



Interface mV



Interface Ethernet



Object Surface



Interface Thermocouple



Explosion Proof Sensor



Temperature Range



Interface USB



Single-Piece Sensor With Electronic In Sensing Head



Size Of Device Under Test And Distance To Sensor



Interface RS232



Two-Piece Sensor With Electronic In Cable



Process Velocity



Interface RS485



Two-Piece Sensor With Sensing Head And Separate Electronic Box



Environmental Conditions



Interface Relay



Single-Piece Sensor With Electronic In Sensing Head



Integration Of Sensors



Interface Profibus DP



Two-Piece Sensor With Sensing Head And Separate Electronic Box

## Optris GmbH

### High quality for contemporary prices

Through the establishment of Optris GmbH, the founder aim to add innovative measuring and application principles to the wide range of non-contact temperature sensors. Doing this, Optris combines high quality infrared thermometers and thermal imagers with contemporary prices, in order to provide the best and modern infrared technology to as many customers as possible.

How does Optris achieve this goal?

The main parts of our basic technology are based on the semiconductor industry. In order to provide progressive technology, Optris cooperates with semiconductor suppliers assuming the sale of high quantities. This leads to the manufacturing of high volumes of infrared sensors and to cost benefits, which we directly forward to our customers.

### Measurement technology made in Germany

Optris GmbH is one of the leading innovative companies in the wide range of non-contact temperature measurement through infrared radiation since its establishment in 2003.

The extensive knowledge and innovative thinking of our well-experienced engineers and physicists allow us to constantly offer optimized solutions for our customers' applications.

The product development, 90 percent of the production and the sales of the products take place at our headquarters in Berlin to ensure a high quality of all products. Due to the close working relationship of each department, we are able to continuously adjust our product range and react fast towards market needs.

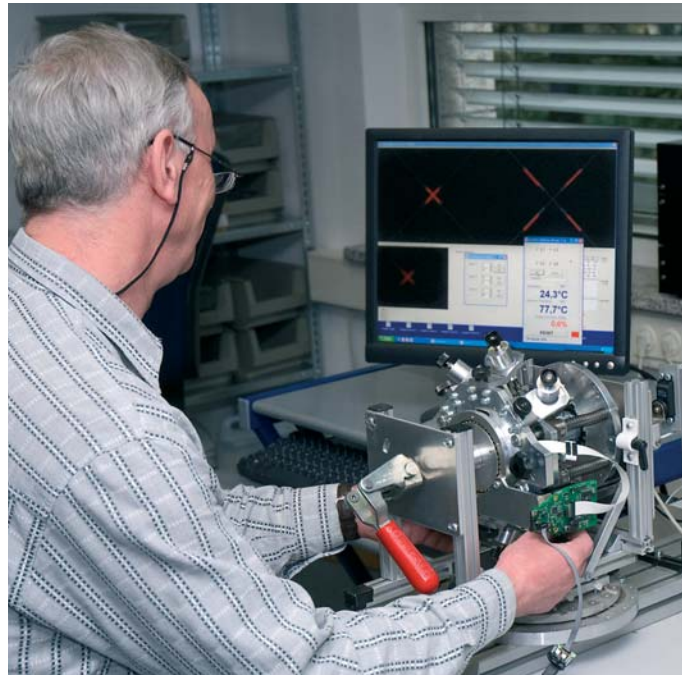

*Highest precision during calibration and laser adjustment of the devices.*



*Mr Dr.-Ing. Ulrich Kienitz, managing director of Optris GmbH*

Our direct sales network consists of well-experienced engineers, who ensure that all of our customers receive competent guidance, solutions for measurement tasks as well as an excellent service.

We have a large network of distributors all over the world to ensure worldwide sales of our products as well as fast and qualified regional customer services. It is of great importance for us that all of our distributors have very good knowledge regarding our products and therefore, they receive regular product training.



*The smallest and most robust sensor within the technology of non-contact temperature measurement; developed and produced by Optris.*

# THE IDEAL MEASUREMENT DEVICE

## Overview of our 4 Product Series

Next to time, temperature is the most frequently measured physical property. Non-contact temperature measurement through infrared radiation is therefore a favoured and established method for many of our customers.

If you have decided to use non-contact temperature sensors for your applications, the question is what would be the ideal device for you. The following three pages will offer you a good overview of the **most important decision criterias** of all our products for an easy device choice.

The following pages covering the **4 product series** will present the uniqueness of each series according to the decision criterias. The indexes on the right site of each page give you an orientation within which product group you are.

### 1. Compact Series

Small, compact infrared thermometers for the ideal use in cramped and hot surroundings

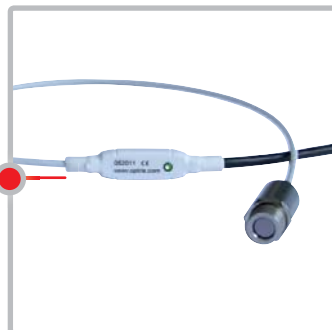

### 2. High Performance Series

Infrared thermometers with highest optical performance and double laser



### 4. Portable Thermometers

High quality infrared thermometers with integrated USB interface

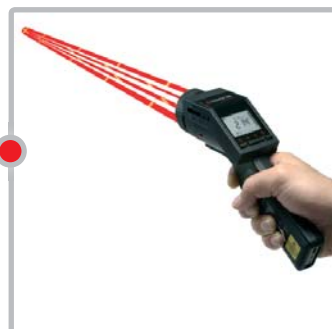

### 3. Infrared Cameras

Compact thermal imagers for fast stationary applications, including linescanner functionality



Spot Measurement or Thermal Image?

First of all, it is important to define the measurement problem and decide between the two following measurement methods:



A selective measuring infrared thermometer

should be used if you know where the critical point or the area to be measured is placed within your application. The size of the measuring object is important to define which lens is necessary. Therefore it is possible to monitor the accurate temperature and optimize processes - if necessary - before quality problems arise.



Infrared cameras,

such as the optris PI, should be used in cases where not only one critical area exists or the area can not be clearly defined. Critical areas can be localized by the camera through the demonstration of thermal images. The areas can then be permanently monitored by one or multiple fixed infrared thermometers.

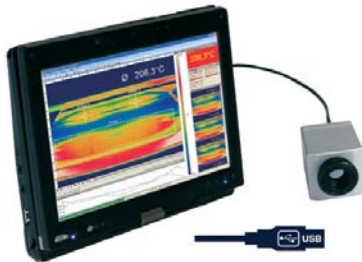

8 - 14 μm for non-metal surfaces (Type of device: LT)



7.9; 4.64; 4.24; 3.9 μm for special applications (Type of device: P7; F6; F2; MT)



5.0 μm for glass surfaces (Type of device: G5)



2.3; 1.6; 1.0 μm mainly for metal surfaces (Type of device: 3M; 2M; 1M)

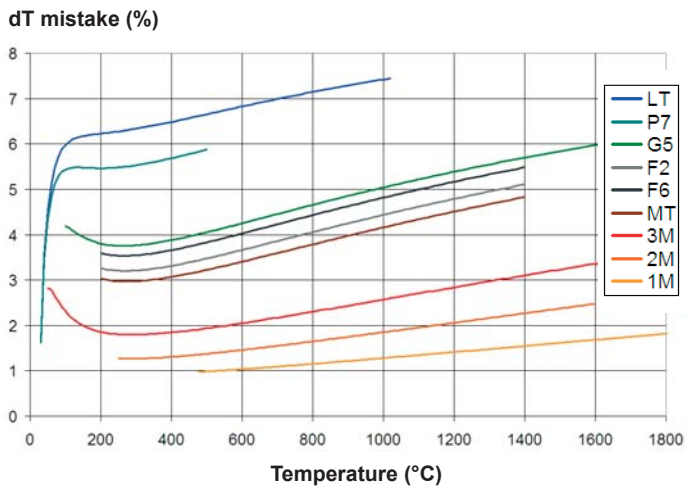

Short wavelength reduce measurement mistakes on surfaces with low, unknown or changing emissivity. This appears mostly with metals. The diagram above shows the measurement mistakes across different wavelength if the emissivity is adjusted wrong by only 10 percent.

Which Temperature Range?



The temperature is an additional factor to decide on. The range should cover all relevant temperatures of the application. Optris offers devices with a measurement range between **-50°C and 1800°C**.

Which Object Surface?



The condition of the object surface defines the measurement device and wavelength to be used for the application. The **emissivity ε** has a central meaning. The choice of the right device is of great importance especially for metals, where the emissivity depends on the temperature and wave length.

Optris offers fitting measurement devices for most applications throughout a wide product range. The following explanation helps to find the right **wavelength** for your application:

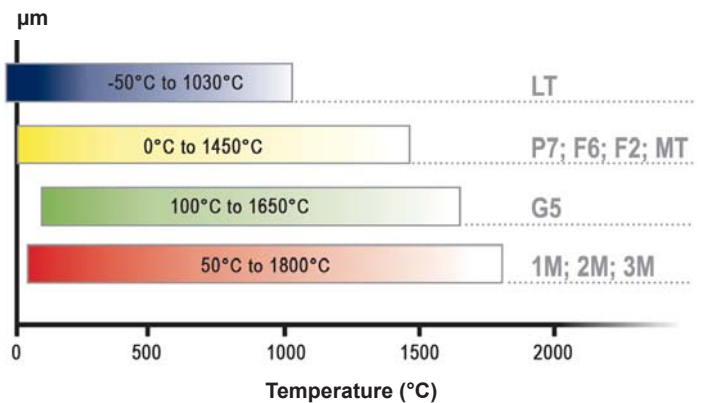

Temperature range of the Optris devices across the wavelength.

## Object Size / Distance to Sensor?



The optical resolution of the checking device is chosen regarding to the **size of the object under test** and the **distance** between the object under test and the sensor. Similar to the emissivity the choice of the wrong lens will lead to extensive temperature differences ( $\Delta T$ ). The spot size of the checking device ( $d_{meas}$ ) is not allowed to be bigger than the size of the checked object ( $d_{real}$ ). Otherwise the following applies:

$$\Delta T_{real} (d_{real} / d_{meas})^2 = \Delta T_{meas} \quad (\text{for } d_{real} \leq d_{meas})$$

An example: Measurement of a SMD component  
 $80^{\circ}\text{C} (5 \text{ mm} / 10 \text{ mm})^2 = 20^{\circ}\text{C}$   
 $80^{\circ}\text{C} (5 \text{ mm} / 5 \text{ mm})^2 = 80^{\circ}\text{C}$



Spot size chosen too big which results in a measurement mistake

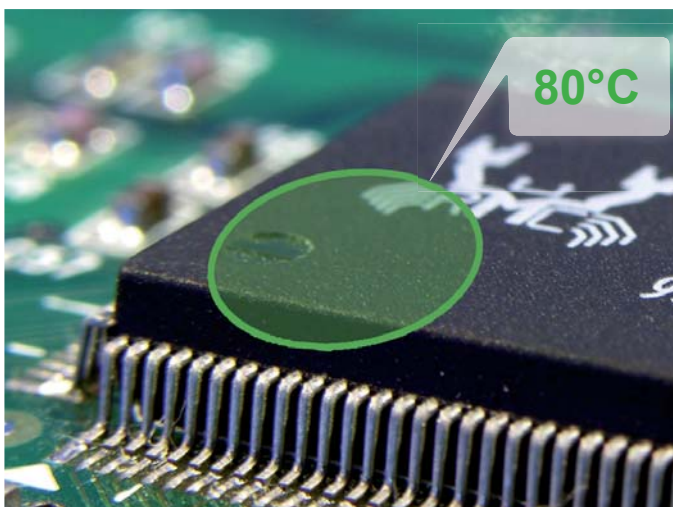

Fitting spot size and correct temperature definition

## Which Process Velocity?

00:00:00

To achieve accurate temperature measurement it is important to know how fast objects under test move in front of the sensor or how fast they change the temperature. The fastest infrared thermometer of Optris captures changes within **1 ms**.

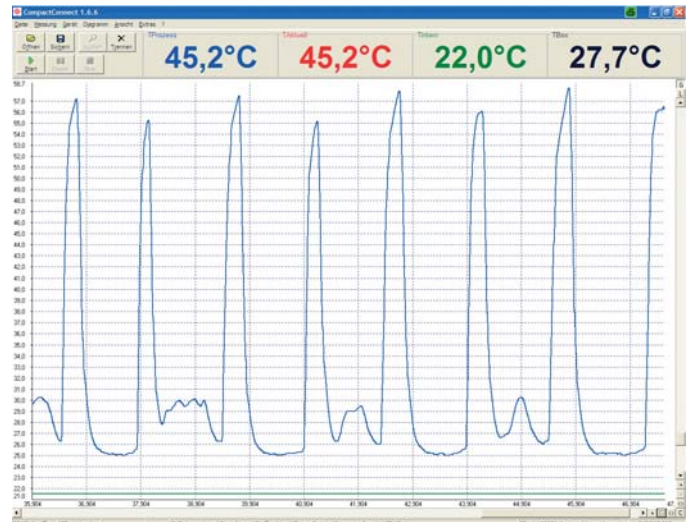

Display of fast temperature changes over a period of time.

## Which Environmental Conditions?



Most sensing heads of Optris consist of an **extremely high temperature resistance**.

The highest acceptable ambient temperature for the optris CThat is **250°C without cooling**.



Stainless steel cooling housing for protection and cooling of the device.

The sensor can be combined with a **cooling jacket** and **air purge collars** for the use in harsh surroundings. The robustness of the devices can therefore be increased.

## Integration of Sensors?



The temperature sensors of Optris can be installed into the process with **mounting brackets** or **flanges**.

Depending on the device, we offer different analog and digital interfaces for **data evaluation** such as triggering, alerting or saving of data.

### Analog Interfaces:

0 - 20 mA, 4 - 20 mA, 0 - 5 mV, 0 - 10 mV,  
Thermocouple (type J, type K)

### Digital Interfaces:

USB, RS232, RS485, Relay, Profibus DP, CAN Bus, Ethernet

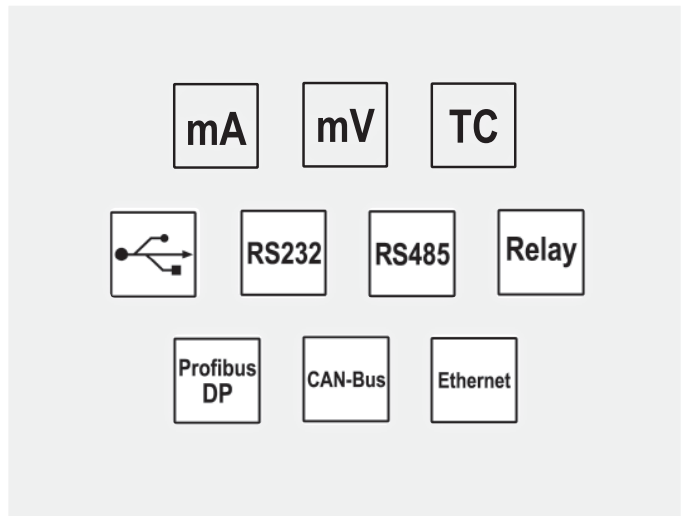



## COMPACT SERIES

Small

Robust

Value for Money

### The Smallest and Most Robust Sensing Head



Optris introduces new benchmarks within the area of industrial infrared thermometers regarding the size and robustness of the sensing heads. The miniaturized sensing heads are especially developed for the use in **small and cramped surroundings** and are perfect for applications with limited space, such as midgest instruments and engine constructions. The very **advantageous cost-performance-ratio** supports the integration within OEM solutions and simultaneous use of the measurement devices at **multiple infrared measuring facilities**.

The compact series devices offer inimitable advantages for the installation in applications with **high ambient temperatures**, such as within the plastic or paper industry. The robust and ambitious design allows the sensing heads to be used for temperatures up to 250°C without additionally cooling. This advantage help to reduce the costs for mechanical installations.

### The Different Device Designs

The first design of the compact series is the **single-piece sensing head**. The lens and electronic are build into a compact housing.



Secondly, Optris developed the two-wire devices with the **electronic integrated within the cable**. The robustness of the sensing heads can therefore be increased. The heat development of the two-wire electronic does not influences the thermal stability of the sensing head.

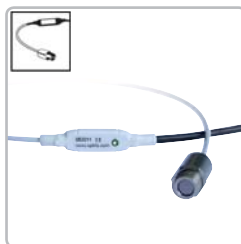

The third alternative is a two-piece device with a **sensing head and a separate electronic box**. The box offers the possibility to choose between different interfaces (see page 26f), additionally to the simple device configuration and a temperature display.



### Proven for Versatile Applications



The compact series covers many applications within the infrared temperature measurement technology. An important, overall segment of the applications is the **OEM market**, especially within the **engine and plant construction**. Operation examples are:



#### Non-metal surfaces (LT)

- Plastic plates at cupping machines
- Laminating of decor and chip tray
- Drying processes within food industry
- Tarmac measurement for roadworks
- Pasteboard and paper drying within offset printer



#### Special applications (P7)

- Plastic foil for blow moulding



#### Glass surfaces (G5)

- Conversion of flat glass



#### Metal surfaces (3M; 2M; 1M)

- **3M**: Measurement through plastic for welding onto carrier material
- **2M**: Melt measurement within melting plants (medical technology)
- **1M**: Shrinking processes

Wide Temperature Range



Depending on the wavelength and the type of device, different temperature ranges can be used. The following areas between **-50°C and 1800°C** are covered by the compact series:

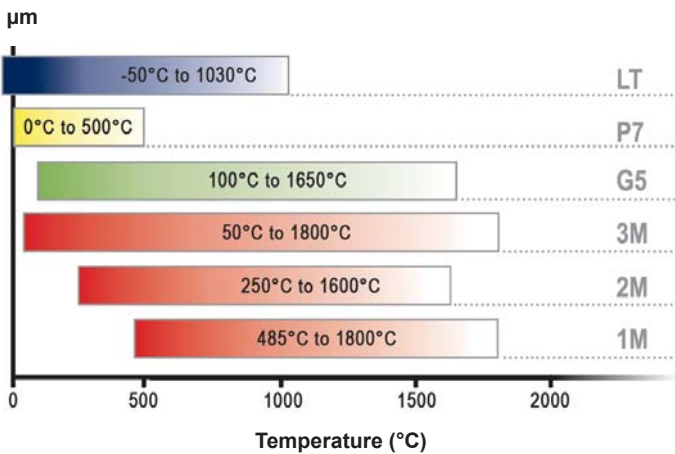

Temperature range of the compact series over the wavelength

Small Spot Sizes within Close and Mean Distances



The lenses of the compact series devices are especially developed for measurements in close and mean distances. The **standard lens** (SF, standard focus) can easily be changed into a **close lens** (CF, close focus) via the ancillary lens.

Example:  
0.6 mm @ 10 mm



Close lens (CF, close focus): Measurement of smallest measurement objects close to the sensor.

Example:  
7 mm @ 1.1 m



Standard lens (SF, standard focus): Measurement of smallest measurement objects in mean distances.

Suitable for Fast Processes



Different measurement velocities (response time) are available to you, depending on the measurement device and the kind of detector. The fastest long wavelength device is the optris CTfast with **6 ms** reaction time. Within the short wave area, difference in temperatures can precisely be measured within **1 ms**.

When Robustness Matters



The sensing heads of the compact series are developed for the installation in areas with high ambient temperatures.

All sensing heads are suitable for temperatures up to 75°C. Some sensing heads consist of an extreme **temperature resistance of up to 250°C**. Therefore, they support time and cost savings, as an additional cooling is not necessary.

If the device will be used in dusty and rough surroundings, an **air purge collar** (standard or laminar) can be combined with the sensing head.

The laminar air purge collar suits at small measurement distances, as it avoids the cooling down of the object due to a sideway air outled.

Additional **massive housings** are available for the M12x1 sensing heads in either brass, anodized aluminium or stainless steel. A protective conduit can be mounted to the housing for reflection protection.



The optris CThot; the sensing head with housing has a temperature resistance up to 250°C without additional cooling.

## The Fitting Interface for Your Measurement Task



Analog and digital interfaces are available for data evaluation depending on the device.

**Additional information** regarding the interfaces can be found on **page 26f**.

## Software for Parameterization and Documentation

The software *optris Compact Connect* allows simple and fast parameterization of the measuring devices and offers documentation of the measurement datas.

**Additional information** regarding the software can be found on **page 24f**.

## Device Example: *optris CS LT* for a Simple Introduction into Multiple Installations

The *optris CS LT* is a small, compact measuring device with an innovative LED display. In general the advantages of the *optris CS LT* are:

### Intelligence of the LED display

- Unique targeting help for sensor adjustments through automatic search of maximum merit (LED: on / off)
- Self-diagnosis with five different display modes (LED: blinking)
- LED display with fulfilled alarm condition, e.g. additionally to the alarm output of the device (LED: on /off)
- Temperature code display (LED: blinking code)

### Security

- Integrated permanent self monitoring (watch dog)
- Status request via LED self diagnosis

### User friendly

- Parameter of emissivity and alarm level via the supply voltage, for single or multiple sensors
- Scalable analog signals
- Drip device via open collector output (visual or acoustic alarm, switch)



*optris CS LT: compact, single-piece sensor for multiple installations*

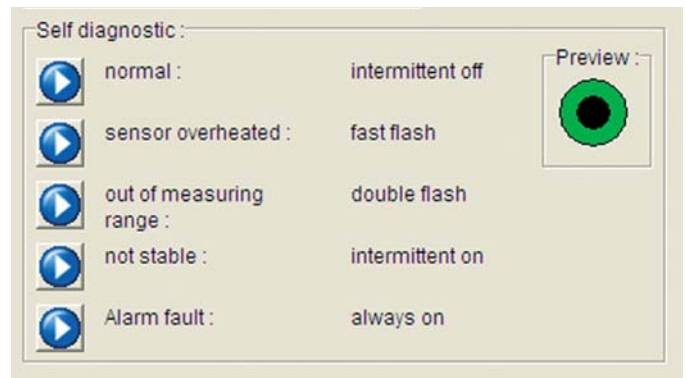

*Explanation of self diagnosis status of the software:*

- 1.) Normal: Device is working normal
- 2.) Sensor overheated: Ambient temperature above 80°C
- 3.) Out of measuring range: Object smaller -40°C or greater 1030°C
- 4.) Not stable: Device thermally instable, e.g. during switch-off or increasing of applied voltage
- 5.) Alarm fault: Open collector switched off, e.g. during fitting of too high voltage

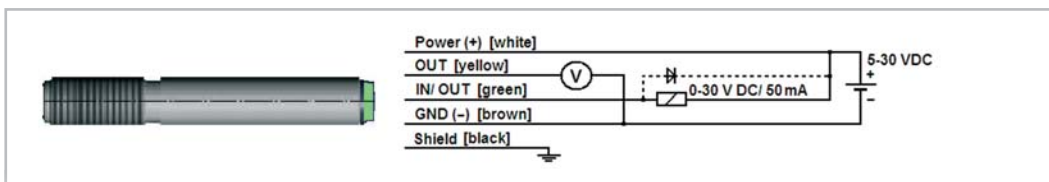

*Device within analog operation with mV signal and alarm output (Open-Collector) at in- / out-pin*

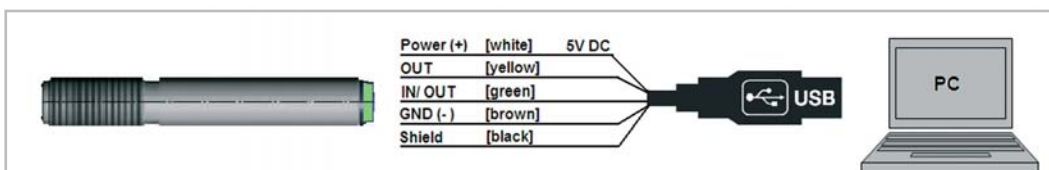

*Device with simultaneous analog & digital operation with complete parameterization possibility via software*

Device Example: Mobile Measurement System for Material Analysis

The optris CTtrans system combines the optris CT LT infrared thermometer with an infrared emitter. It assigns the material parameter transmission for different previous materials (e.g. foils). The definition of the reflectivity is also possible. Both **parameters (transmission, reflectivity)** can be passed on manually or automatically to an additional infrared thermometer or to the **PLC**. This is in use to define the temperature for changing material properties during manufacturing processes, for example.

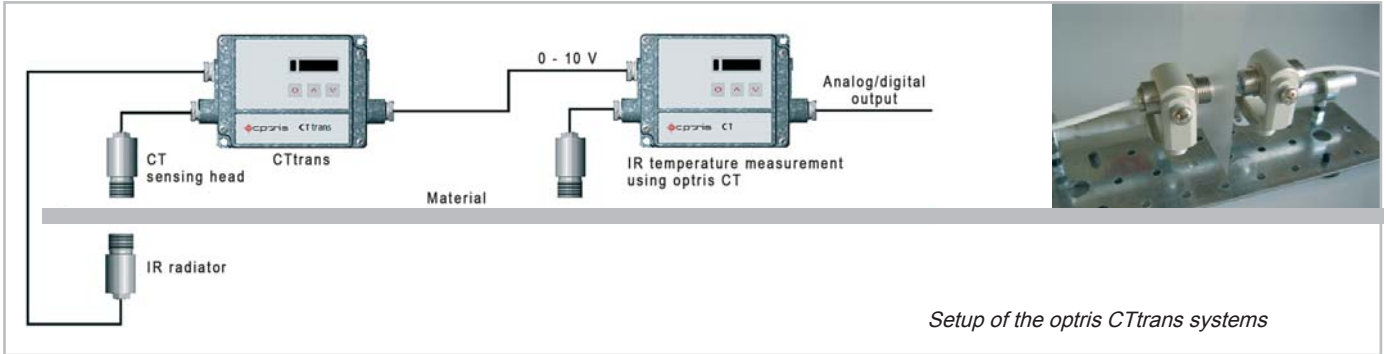

Device Example: optris CT LT for the Use in Explosive Areas

The sensing heads of the optris CT LT devices belong to the category simple electronic current assets according to EN 50014. As no special certificate for intrinsic safety is necessary, the devices can be used as **passive elements** within **explosive areas**.

Indemnification for the intrinsic safety is secured through the boundary of the energy supplied to the sensing head with two Zener double batteries of the type 9002/22-032-300-111 (R. STAHL AG). Therefore they are allowed to be used in zone 1 (PTB 01 ATEX 2053/ E II (1/2) GD [EEx ia/ib] IIC/IIB).

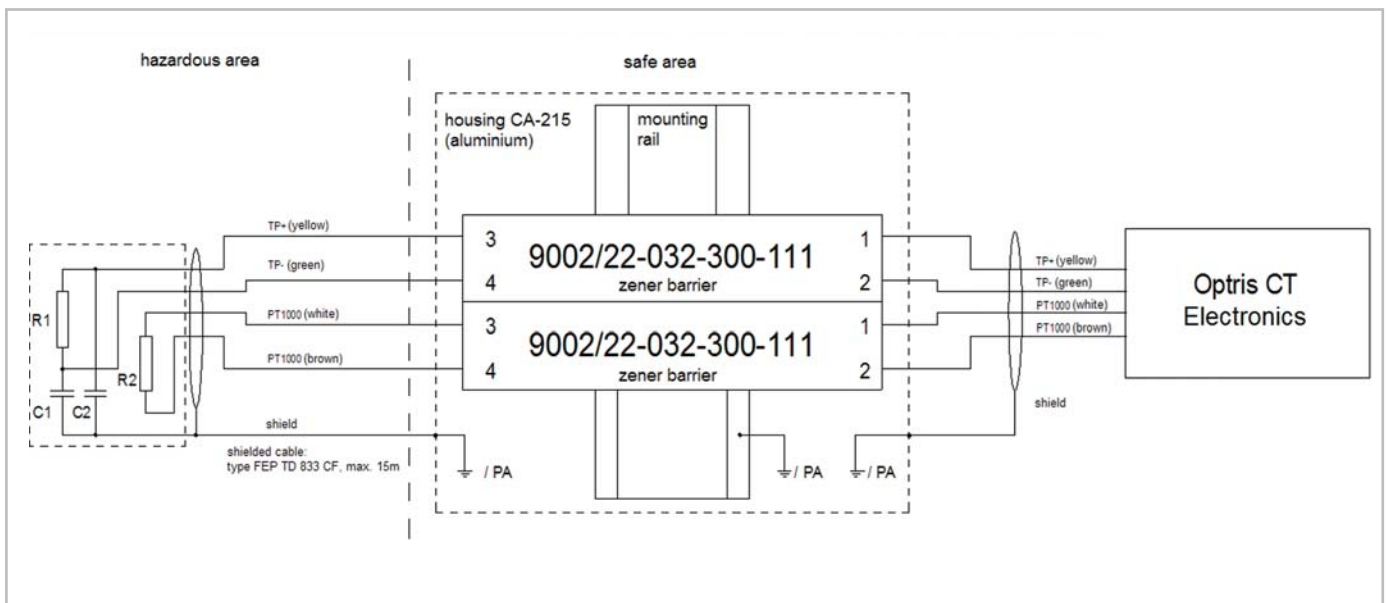
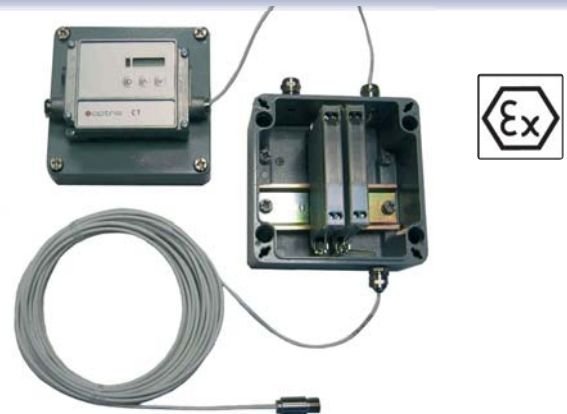

*Setup of the optris CT LT devices for the use in Ex protected areas.*

## Mechanical Accessories



Mounting angle, adjustable in one axis (M12x1-sensing head, massive housing, 2-hole for M12x1)



Mounting bolt for M12x1 sensing head, adjustable in one axis



Mounting fork for M12x1 sensing head, adjustable in two axes

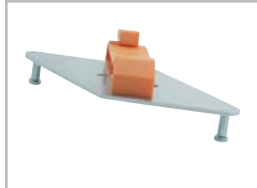

Rail mount adapter, for CT electronic box



Closed device cover, for CT electronic box

## Optical Accessories



CF ancillary lens or protection window, for M12x1 sensing head



CF ancillary lens or protection window, for air purge collar (laminar) or massive housing



OEM laser sight support, supply via CT electronic box or batteries



Rectangular mirror for measurement with 90° to sensor axis



Reflection protection pipe and pipe adapter, for M12x1 sensing head

## Air purges and protection housings



Air purge collar, for M12x1 sensing head



Air purge collar, for massive housing



Air purge collar laminar, for M12x1 sensing head



Air purge collar, available in brass or anodized aluminium, for M12x1 sensing head



Massive housing, available in brass, anodized aluminium or stainless steel

## Examples of Possible Combination of Accessory Parts of the Compact Series



Air purge collar, laminar

+



Mounting fork

=



Device adjustable in two axes



Mounting angle (2-hole)

+



OEM laser sight support

=



Sensing head with laser sight support



Mounting angle for M12x1 sensing head

+



Mounting bolt

=



Device adjustable in two axes



Massive housing, stainless steel

+















Air purge collar, stainless steel

=



Massive housing with air purge collar

Base Model	CS	CSmicro	CSmicro 2W	CSmicro 2W	CSmicro 2W
Type	LT	LT02 / LT15	LT15 / LT15H	LT hs	2M
					
Classification / special features	Single-piece sensor with smart LED display (self diagnostics, aiming support, alarm, temperature code)	Single-piece piece sensor with electronics in cable and smart LED display (aiming support alarm etc.)	Single-piece two-wire sensor with electronics in cable	Single-piece two-wire sensor with electronics in cable with high thermal sensitivity	Single-piece two-wire sensor with electronics in cable for metal applications
Detector	Thermopile	Thermopile	Thermopile	Thermopile	InGaAs
Sensing head exchangeable	-	-	-	-	-
Head cable shortening	■	■ (after electronics)	■ (after electronics)	■ (after electronics)	■ (after electronics)
Thread (sensing head)	M12x1	M12x1	M12x1	M12x1	M12x1
Spectral range	8-14 μm	8-14 μm	8-14 μm	8-14 μm	1.6 μm
Temperature ranges	-40°C...1030°C	-40°C...1030°C	-40°C...1030°C	-20°C...150°C	385°C...1600°C
Temperature resolution	0.1°C	0.1°C	0.1°C	0.025°C [>20°C]	0.1°C
Optical resolution	15:1	2:1 / 15:1	15:1	15:1	75:1
Option: CF lens	■	■	■	■	■
Smallest spot (CF optics / add. CF lens)	0.8 mm @ 10 mm	2.5 mm @ 23 mm / 0.8 mm @ 10 mm	0.8 mm @ 10 mm	0.8mm@ 10mm	1.5 mm @ 110 mm
Smallest spot (SF optics)	7 mm	7 mm	7 mm	7 mm	7 mm
Sighting	LED aiming	LED aiming	LED aiming	LED aiming	LED aiming
Response time (90%)	25 ms	30 ms	30 ms	150 ms	10 ms
Accuracy	±1.5°C or ±1.5%	±1.5°C or ±1.5%	±1.5°C or ±1%	±1°C or ±1%	±(0.3% T <sub>Meas</sub> +2°C)
Outputs analog: 0-20 mA / 4-20 mA / 0-5 V / 0-10 V / t/c (K/J)	- / - / ■ / ■ / -	- / - / ■ / ■ / -	- / ■ / - / - / -	- / ■ / - / - / -	- / ■ / - / - / -
Second analog output	-	-	-	-	-
Interfaces: USB / RS232 / RS485 / Profibus / Ethernet	■ / - / - / - / -	■ / - / - / - / -	■ / - / - / - / -	■ / - / - / - / -	■ / - / - / - / -
Signal processing: Peak / Valley / AVG / Advanced hold	■ / ■ / ■ / ■	■ / ■ / ■ / ■	■ / ■ / ■ / ■	■ / ■ / ■ / ■	■ / ■ / ■ / ■
T <sub>Amb</sub> Head min.	-20°C	-20°C	-20°C	-20°C	-20°C
T <sub>Amb</sub> Head max.	80°C	120°C	120°C / 180°C	75°C	125°C
T <sub>Amb</sub> Electronics max.	80°C	80°C	75°C	75°C	75°C
Functional inputs / number	■ / 1	■ / 1	- / -	- / -	- / -
External emissivity adjustment	■ (via Vcc adjust)	■ (via Vcc adjust)	-	-	-
External background temperature control	■	■	-	-	-
Trigger input for reset of hold functions	■	■	-	-	-
Digital I/O pins	-	-	-	-	-
Simultaneous analog and digital output	-	-	■	■	■
Alarm output alternatively to analog output	■	■	■	■	■
Additional alarm output	■	■	■	■	■
Power supply	5-30 VDC	5-30 VDC	5-30 VDC	5-30 VDC	5-30 VDC
Standard cable length	1 m	1 m	1 m	4 m	1 m
Cable length options	3 / 8 / 15 m	-	-	-	-

CT	CTfast	CThot	CT	CT	CT	CT
LT02 / LT15 / LT22	LT15F / LT25F	LT02H / LT10H	1M / 2M	3M	G5	P7
						
Two-piece sensor with separate electronic box incl. programming keys and temperature display	Two-piece sensor with fast response time and separate electronic box incl. programming keys and temperature display	Two-piece sensor for hot surroundings feat. a separate electronic box incl. programming keys and display	Two-piece sensor for high temp. meas. of metal feat. a separate electronic box incl. progr. keys and display	Two-piece sensor for mid temp. meas. of metal feat. a separate electronic box incl. progr. keys and display	Two-piece sensor for temp. meas. of glass feat. a separate electronic box incl. progr. keys and display	Two-piece sensor for temp. meas. at plastic foils feat. a separate electronic box incl. progr. keys and display
Thermopile	Thermopile	Thermopile	Si / InGaAs	Extended InGaAs	Thermopile	Thermopile
■	-	-	■ [+Ct laser 1M/2M]	■ [+Ct laser 3M]	■	-
■ [-0.1 K/m]	■ [max. 3 m]	■ [-0.1 K/m]	■ [max. 3 m]	■	■ [-0.1 K/m]	-
M12x1	M12x1	M18x1	M12x1	M12x1	M12x1	M18x1
8-14 μm	8-14 μm	8-14 μm	1.0 / 1.6 μm	2.3 μm	5.0 μm	7.9 μm
-50°C...600°C / -50°C...600°C / -50°C...975°C	-50°C...975°C	-40°C...975°C	1ML: 485...1050°C 1MH: 650...1800°C 2ML: 250...800°C 2MH: 385...1600°C	L: 50...400°C H: 100...600°C H1: 150...1000°C H2: 200...1500°C H3: 250...1800°C	L: 100...1200°C H: 250...1650°C	0°C...500°C
0.1°C	0.2°C / 0.4°C	0.25°C	0.1°C	0.1°C	L:0.1°C/ H:0.2°C	0.5°C
2:1 / 15:1 / 22:1	15:1 / 25:1	2:1 / 10:1	L:40:1 / H:75:1	L:22:1/ H:33:1/ H1-H3: 75:1	L:10:1/ H:20:1	10:1
■	■	■	■	■	-	-
2.5 mm @ 23 mm / 0.8 mm @ 10 mm / 0.6 mm @ 10 mm	0.8 mm @ 10 mm 0.5 mm @ 10 mm	2.5 mm @ 23 mm / 1.2 mm @ 10 mm	1.5 mm @ 110 mm	3.4 mm @ 110 mm	-	-
7 mm	7 mm	7 mm	7 mm	7 mm	7 mm	7 mm
-	-	-	-	-	-	-
150 ms	9 ms / 6 ms	100 ms	1 ms	1 ms	L:120 / H:80 ms	150 ms
±1°C or ±1%	±2°C or ±1%	±1.5°C or ±1%	±(0.3% T <sub>Meas</sub> +2°C)	±(0.3% T <sub>Meas</sub> +2°C)	±2°C or ±1%	±1.5°C or ±1%
■ / ■ / ■ / ■ / ■	■ / ■ / ■ / ■ / ■	■ / ■ / ■ / ■ / ■	■ / ■ / ■ / ■ / ■	■ / ■ / ■ / ■ / ■	■ / ■ / ■ / ■ / ■	■ / ■ / ■ / ■ / ■
■	■	■	-	-	■	■
■ / ■ / ■ / ■ / ■	■ / ■ / ■ / ■ / ■	■ / ■ / ■ / ■ / ■	■ / ■ / ■ / ■ / ■	■ / ■ / ■ / ■ / ■	■ / ■ / ■ / ■ / ■	■ / ■ / ■ / ■ / ■
■ / ■ / ■ / ■	■ / ■ / ■ / ■	■ / ■ / ■ / ■	■ / ■ / ■ / ■	■ / ■ / ■ / ■	■ / ■ / ■ / ■	■ / ■ / ■ / ■
-20°C	-20°C	-20°C	-20°C	-20°C	-20°C	-20°C
130°C / 180°C / 180°C	120°C	250°C	100°C / 125°C	85°C	85°C	85°C
85°C	85°C	85°C	85°C	85°C	85°C	85°C
■ / 3	■ / 3	■ / 3	■ / 3	■ / 3	■ / 3	■ / 3
■	■	■	■	■	■	■
■	■	■	■	■	■	■
■	■	■	■	■	■	■
-	-	-	-	-	-	-
■	■	■	■	■	■	■
■	■	■	■	■	■	■
8-36 VDC	8-36 VDC	8-36 VDC	8-36 VDC	8-36 VDC	8-36 VDC	8-36 VDC
1 m	1 m	3 m	3 m	3 m	3 m	3 m
3 / 8 / 15 m	3 / 8 / 15 m	8 / 15 m	8 / 15 m	-	8 / 15 m	8 / 15 m

Compact Series  
High Performance Series  
Infrared Cameras  
Portable Thermometers

### Application Example: Process Control at Thermoforming

Plastic processors are producing a wide range of plastic products with different dimensions, thickness, textures, colors and embossing examples.

The production of products lays within multiple thermal processes. Infrared thermometers are used for **temperature measurement and control**, if the **critical areas** within the process are known.

An important operational area is the installation in thermoforming machinery. Within thermoforming processes, the base material will be heated with emitters and thermally homogenized. A correct setup of the **forming temperature** and its **high homogeneity** will lead to high quality forming processes.

Infrared thermometers such as the optris CT LT will be setup in one line at the **heating zone exit** to monitor the temperature profile and visualize temperature gradients.

#### Advantages of the optris CT LT:

- Installation of multiple sensors (e.g. via RS485) for process control, e.g. at a line
- Capturing of smallest temperature differences
- Monitoring of foil temperature and optimization of product quality
- Display and outlay of individual temperature data via the electronic box or SPS
- Batch specific documentation of temperature data

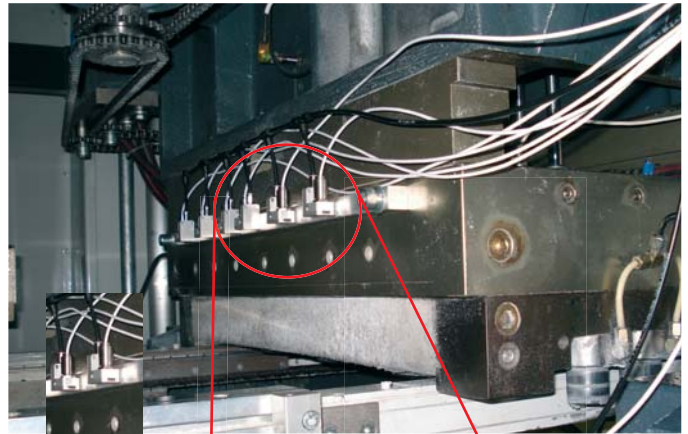

*Small optris CT LT sensing heads installed in a machinery with a laminar air purge collar.*



# HIGH PERFORMANCE SERIES

Smallest Spot Size

Accurate Measurement Field  
Marking through Laser Sight

## Sensors with High Optical Performance and Innovative Laser Sighting



The devices of the product group consist of an **innovative double laser sighting**, in contrast to many pyrometers with single lasers which only mark the middle but not the size of the spot. The two emitters are following the infrared optical path to mark the **accurate size and spot of the measuring field** at every distance. Measurement mistakes will therefore be avoided.

The infrared thermometers of this class are mainly used in industrial area as well as research and development. **Small measurement field sizes** are of great importance for precise temperature measurement. The smallest spot size is marked by the cross over point of the two laser sights. The optris CTlaser 1M, for example, achieves a measurement field size of 0.5 mm in 150 mm distance. Additionally, a number of different lenses allow a **flexible adjustment** for the single applications.

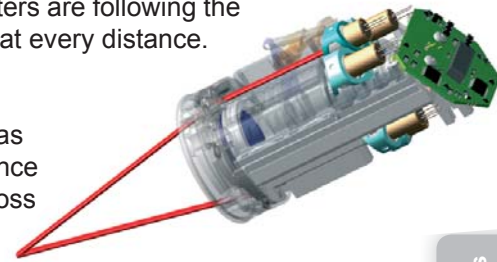

## The Different Device Designs

The first design of the high performance series is the **single-piece sensing head**. Lens and electronic are obstructed within a compact device.



Furthermore a two-piece design is available consisting of the **sensing head** and **separate electronic box**.

The box offers the possibility to choose between different interfaces (see page 26f), additionally to the simple device configuration and a temperature display.



The ratio pyrometer combines the **sensing head** and the **separate electronic box** by a **glass fiber cable**.

Both the sensing head and the glass fiber cable are usable for up to **250°C** ambient temperature without additional cooling.



## When Optical Performance Counts



An important, overall segment of the applications is the **OEM market**, especially within the **engine and plant construction**.

But also **R&D departments** and universities use the devices of this class, if very good optical device parameters are needed. Application examples are:



### Non-metal surfaces (LT)

- Welding of plastic parts
- Test stations within automobile industry



### Special applications (P7, F6, F2, MT)

- **P7:** Production of foils (PES, PTFE)
- **F6:** Combustion gas in waste burning machinery
- **F2:** Combustion gas in reactors
- **MT:** Temperature measurement of ceramics and glass through flames



### Glass surfaces (G5)

- Production of laboratory glass
- Glass bottles and container glass



### Metal surfaces (3M; 2M; 1M)

- **3M:** Induction heating of battery terminals
- **2M:** Induction hardening of cog wheels
- **1M:** Pipe welding processes

## Wide Temperature Range



The temperature range of the high performance series lays between **-50 °C and 1800°C**, depending on the wavelength and the type of device.

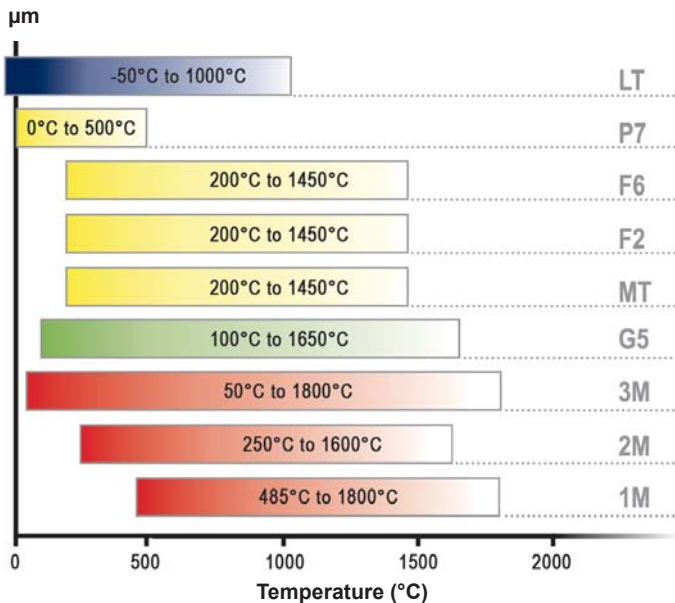

Temperature range of the high performance series over the wavelength

## Smallest Spot Size at Every Distance



The high performance series is used, where a **high optical resolution** as well as an **accurate measurement field marking through a laser sighting** is of great importance. Therefore, a perfect adjustment of the devices is possible. The following lenses are available.

Example:  
0.5 mm @ 150 mm



Close lens (CF, close focus): Measurement of smallest measurement objects close to the sensor.

Example:  
3.7 mm @ 1.1 m



Standard lens (SF, standard focus): Measurement of smallest measurement objects in mean distances.

Example:  
12 mm @ 3.6 m



Far lens (FF, far focus): Measurement of smallest measurement objects in greater distances.

## Suitable for Fast Processes



Different measurement velocities (response time) are available to you depending on the measurement device and the kind of detector. The fastest long wavelength device is the optris CTlaser LTF with **9 ms** reaction time. Within the short wave area difference in temperatures can precisely be measured within **1 ms**.



The high performance series is characterized by a great local resolution and a fast response time.

## Accessories for Rough Surroundings



All sensing heads of the high performance series are suitable for ambient temperatures up to **85°C**. The lasers are automatically turned off at 50°C.

**Air purge collars** are available in different sizes depending on the kind of device. The sensing head will therefore be protected from dirt and environmental influences.

We suggest the use of the **cooling jacket** (operation temperature up to 175°C) for applications with higher ambient temperatures.

The optional **cooling housing** protects the measuring head within hot surroundings through cooling with air up to 100°C and cooling through water up to 240°C. High temperature resistant cables are available for the housings.



Complete oven armature consisting of measurement device, cooling jacket, air purge collar, protection pipe and flanch.

## The Appropriate Interface for your Measurement Task



Analog and digital interfaces are available for data evaluation depending on the device.

**Additional information** regarding the interfaces can be found on **page 26f**.

## Software for Parameterization and Documentation

The software optris Compact Connect allows simple and fast parameterization of the measuring devices and offers documentation of the measurement datas.

**Additional information** regarding the software can be found on **page 24f**.

## Device Example: optris CSLaser LT - High Performance in One Box

The optris CSLaser LT has been developed for customers of the manufacturing industry. It is a **single-piece, strong performance device** with integrated lens and electronic and can measure temperatures at **very small objects**. The device is suitable for temperature measurement at products, but also at machineries or tools. More and more OEM customers recognise it as an indispensable device due to the high replaceability.

The optris CSLaser LT offers an analog **two-wire-interface** (4-20 mA current loop) which is very common in the industry. An additional alarm output (open-collector, 0-30 V, 500 mA) is a product benefit which is not common around two-wire-sensors.

The device can simultaneously sent digital datas to a PC via an USB interface. The implementation of the sensor into the software optris Compact Connect allows the collection of temperature data as well as a complete parameterization of the sensor.



*Double laser sight for accurate measurement field marking in every distance, e.g. 0.5 mm at 150 mm distance.*



*Simple emissivity setup between 0.10...1.09 and individual cabling directly at the sensing head.*

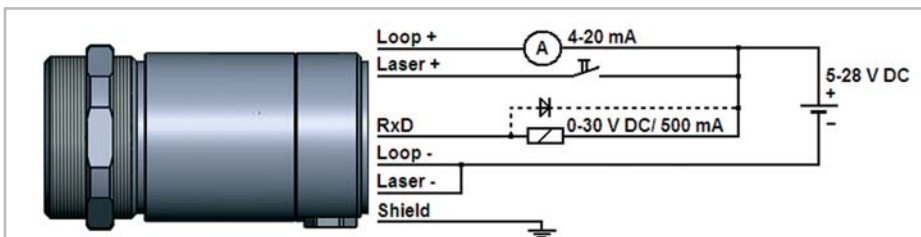

*Device analog operation with 4-20mA signal and alarm output (open-Collector) at in- / out-pin*

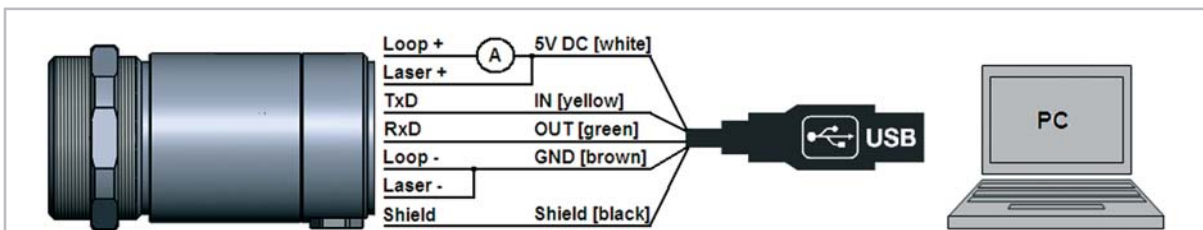

*Device with simultaneous analog & digital operation with complete parameterization possibility via software*

## Accessories

				
Mounting angle, adjustable in one axis	Mounting angle, adjustable in two axes	Air purge collar	Cooling jacket	Cooling housing
				
Mounting angle, for cooling housing, adjustable in two axes	Mounting adapter, for protective pipe or cooling housing	Protection pipe and pipe adapter, for cooling housing	Rail mount adapter, for CT electronic box	Closed box cover, for CT electronic box

## Examples of Possible Combination of Accessories for High Performance Series

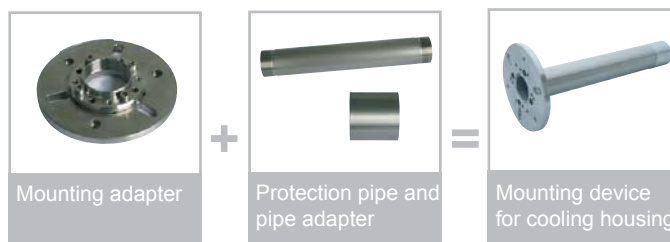

## Application Example: Temperature Measurement during Induction Hardening

Heat treatment gained high importance within the metal industry. Characteristics, such as corrosion resistance, magnetism, hardness, ductility, scuff resistance and breaking behaviour can be influenced by targeted heat treatment.

**Induction heating** is one kind of heat treatment. Workpieces are brought into a strong electromagnetic field, therefore heated and finally freezed in a defined texture.

It is possible to locally define the depth of impression of the heat into the material by controlling the frequency. The aimed texture structure of the metal depends on the ideal temperature time process. Therefore it is important to permanently monitor the temperature.

Due to high electronicmagnetic fields, the optris CTlaser 1M, 2M and 3M are ideal for this application as the electronic is seperated from the sensing head and therefore protected from the radiation.







### Advantages of the optris CTlaser 1M / 2M / 3M:

- Wavelength especially for metal surfaces (1  $\mu\text{m}$  / 1.6  $\mu\text{m}$  / 2.3  $\mu\text{m}$ )
- Reliable temperature measurement of metal from 50°C up to 1800°C
- Fast temperature control through measurements within 1 ms
- Measurement of smallest parts through high optical resolution (measurement field starting from 0.7 mm)



*optris CTlaser devices for the use at induction hardening.*

Base Model	CSlaser	CSlaser	CTlaser	CTlaser	CTlaser
Type	LT / LT hs	2M	LT	LTF	1M
					
Classification / special features	Single-piece two-wire sensor with electronics in sensing head, high optical resolution and double laser	Single-piece two-wire sensor with electronics in sensing head for measurement of metal feat. double laser	Two-piece sensor with separate electronic box, high optical resolution and double laser	Two-piece sensor with separate electronic box with fast response time feat. high optical resolution, double laser	Two-piece sensor with separate electronic box for high temp. measurement of metal feat. double laser
Detector	Thermopile	InGaAs	Thermopile	Thermopile	Si
Sensing head exchangeable	-	-	■	■	■ [+CT 1M]
Head cable shortening	■	■	■ [max. 6 m]	■ [max. 6 m]	■ [max. 6 m]
Thread (sensing head)	M48x1.5	M48x1.5	M48x1.5	M48x1.5	M48x1.5
Spectral range	8-14 μm	1.6 μm	8-14 μm	8-14 μm	1.0 μm
Temperature ranges	-30°C...1000°C / -20°C...150°C	385°C...1600°C	-50°C...975°C	-50°C...975°C	L: 485...1050°C H: 650...1800°C
Temperature resolution	0.1°C / 0.025°C	0.1°C	0.1°C	0.5°C	0.1°C
Optical resolution	50:1	300:1	75:1	50:1	L: 150:1 / H: 300:1
Option: CF lens	-	-	-	-	-
Smallest spot (CF optics / add. CF lens)	1.4 mm @ 70 mm	0.5 mm @ 150 mm	0.9 mm @ 70 mm	1.4 mm @ 70 mm	0.5 mm @ 150 mm
Smallest spot (SF optics)	24 mm @ 1200 mm	3.7 mm @ 1100 mm	16 mm @ 1200 mm	24 mm @ 1200 mm	3.7 mm @ 1100 mm
Sighting	Double laser	Double laser	Double laser	Double laser	Double laser
Response time (90%)	150 ms	10 ms	120 ms	9 ms	1ms
Accuracy	±1°C or ±1%	±(0.3% T <sub>Meas</sub> +2°C)	±1°C or ±1%	±1.5°C or ±1.5%	±(0.3% T <sub>Meas</sub> +2°C)
Outputs analog: 0-20 mA / 4-20 mA / 0-5 V / 0-10 V / t/c (K/J)	- / ■ / - / - / -	- / ■ / - / - / -	■ / ■ / ■ / ■ / ■	■ / ■ / ■ / ■ / ■	■ / ■ / ■ / ■ / ■
Second analog output	-	-	■	■	-
Interfaces: USB / RS232 / RS485 / Profibus / Ethernet	■ / - / - / - / -	■ / - / - / - / -	■ / ■ / ■ / ■ / ■	■ / ■ / ■ / ■ / ■	■ / ■ / ■ / ■ / ■
Signal processing: Peak / Valley / AVG / Advanced hold	■ / ■ / ■ / ■	■ / ■ / ■ / ■	■ / ■ / ■ / ■	■ / ■ / ■ / ■	■ / ■ / ■ / ■
T <sub>Amb</sub> Head min.	-20°C	-20°C	-20°C	-20°C	-20°C
T <sub>Amb</sub> Head max.	85°C	85°C	85°C	85°C	85°C
T <sub>Amb</sub> Electronics max.	85°C	85°C	85°C	85°C	85°C
Functional inputs / number	- / -	- / -	■ / 3	■ / 3	■ / 3
External emissivity adjustment	-	-	■	■	■
External background temperature control	-	-	■	■	■
Trigger input for reset of hold functions	-	-	■	■	■
Digital I/O pins / number	-	-	-	-	-
Simultaneous analog and digital output	■	■	■	■	■
Alarm output alternatively to analog output	■	■	■	■	■
Additional alarm output	■	■	■	■	■
Power supply	5-30 VDC	5-30 VDC	8-36 VDC	8-36 VDC	8-36 VDC
Standard cable length	3 m	3 m	3 m	3 m	3 m
Cable length options	8 / 15 m	8 / 15 m	8 / 15 m	8 / 15 m	8 / 15 m

CTlaser	CTlaser	CT XL	CTlaser	CTlaser	CTlaser	CTratio
2M	3M	3M	MT / F2 / F6	G5	P7	1M
						
Two-piece sensor with separate electronic box for high temp. measurement of metal feat. double laser	Two-piece sensor with separate electronic box for mid temp. measurement of metal feat. double laser	Two-piece sensor with separate electronic box for laser applications feat. high optical resolution (no laser)	Two-piece sensor for measurement: MT: through flames F2: CO <sub>2</sub> flame gas F6: CO flame gas	Two-piece sensor with separate electronic box for measurement of glass feat. high optical resolution, double laser	Two-piece sensor with separate electronic box for measurement of plastic foils feat. double laser	Ratio pyrometer with separate electronic box for high temp. meas. of metal feat. glass fiber cable and laser
InGaAs	Extended InGaAs	Extended InGaAs	Thermopile	Thermopile	Thermopile	Si sandwich
■ [+CT 2M]	■ [+CT 3M]	-	■	■	■	-
■ [max. 6 m]	■ [max. 6 m]	■	■ [max. 6 m]	■ [max. 6 m]	■ [max. 6 m]	-
M48x1.5	M48x1.5	M30x1	M48x1.5	M48x1.5	M48x1.5	M18x1
1.6 μm	2.3 μm	2.3 μm	3.9 / 4.24 / 4.64 μm	5.0 μm	7.9 μm	0.7 to 1.1 μm
L: 250...800°C H: 385...1600°C	L: 50...400°C H: 100...600°C H1: 150...1000°C H2: 200...1500°C H3: 250...1800°C	H: 100...600°C H1: 150...1000°C H2: 200...1500°C H3: 250...1800°C	200°C...1450°C	L: 100...1200°C H: 250...1650°C	0°C...500°C	700°C...1800°C
0.1°C	0.1°C	0.1°C	0.1°C	L:0.1°C/ H:0.2°C	0.5°C	0.1°C (>900°C)
L: 150:1/ H: 300:1	L: 60:1/ H: 100:1/ H1-H3: 300:1	H: 100:1 H1-H3: 300:1	45:1	L:45:1/ H:70:1	45:1	40:1
-	-	-	-	-	-	-
0.5 mm @ 150 mm	0.7 mm @ 70 mm	0.7 mm @ 70 mm	1.6 mm @ 70 mm	1 mm @ 70 mm	1.6 mm @ 70 mm	7.7 mm @ 305 mm
3.7 mm @ 1100 mm	11 mm @ 1100mm	11 mm @ 1100mm	27 mm @ 1200 mm	17 mm @ 1200 mm	27 mm @ 1200 mm	31.3 mm @ 1143 mm
Double laser	Double laser	-	Double laser	Double laser	Double laser	Laser
1 ms	1 ms	1 ms	10 ms	L:120/ H:80ms	150 ms	5 ms
±(0.3% T <sub>Meas</sub> +2°C)	±(0.3% T <sub>Meas</sub> +2°C)	±(0.3% T <sub>Meas</sub> +2°C)	±1.5°C or ±1%	±1°C or ±1%	±1.5°C or ±1%	±(0.5% T <sub>Meas</sub> +1°C)
■ / ■ / ■ / ■ / ■	■ / ■ / ■ / ■ / ■	■ / ■ / ■ / ■ / ■	■ / ■ / ■ / ■ / ■	■ / ■ / ■ / ■ / ■	■ / ■ / ■ / ■ / ■	■ / ■ / ■ / ■ / -
-	-	-	■	■	■	-
■ / ■ / ■ / ■ / ■	■ / ■ / ■ / ■ / ■	■ / ■ / ■ / ■ / ■	■ / ■ / ■ / ■ / ■	■ / ■ / ■ / ■ / ■	■ / ■ / ■ / ■ / ■	■ / ■ / ■ / ■ / ■
■ / ■ / ■ / ■	■ / ■ / ■ / ■	■ / ■ / ■ / ■	■ / ■ / ■ / ■	■ / ■ / ■ / ■	■ / ■ / ■ / ■	■ / ■ / ■ / ■
-20°C	-20°C	-20°C	-20°C	-20°C	-20°C	-20°C
85°C	85°C	85°C	85°C	85°C	85°C	250°C
85°C	85°C	85°C	85°C	85°C	85°C	85°C
■ / 3	■ / 3	■ / 3	■ / 3	■ / 3	■ / 3	- / -
■	■	■	■	■	■	-
■	■	■	■	■	■	-
■	■	■	■	■	■	■ (via I/O pins)
-	-	-	-	-	-	■ / 2
■	■	■	■	■	■	■
■	■	■	■	■	■	■
■	■	■	■	■	■	■ (via I/O pins)
8-36 VDC	8-36 VDC	8-36 VDC	8-36 VDC	8-36 VDC	8-36 VDC	8-36 VDC
3 m	3 m	3 m	3 m	3 m	3 m	3 m
8 / 15 m	8 / 15 m	-	8 / 15 m	8 / 15 m	8 / 15 m	6 / 10 / 15 / 22 m

Compact Series

High Performance Series

Infrared Cameras

Portable Thermometers



### Extensive software

- No additional costs
- No restrictions in licencing
- Modern software with intuitively operating interface
- Complete parameterization of sensors via the software
- Display of data from multiple sensors in different windows
- Compatible with Windows XP, Vista and 7\*

1.

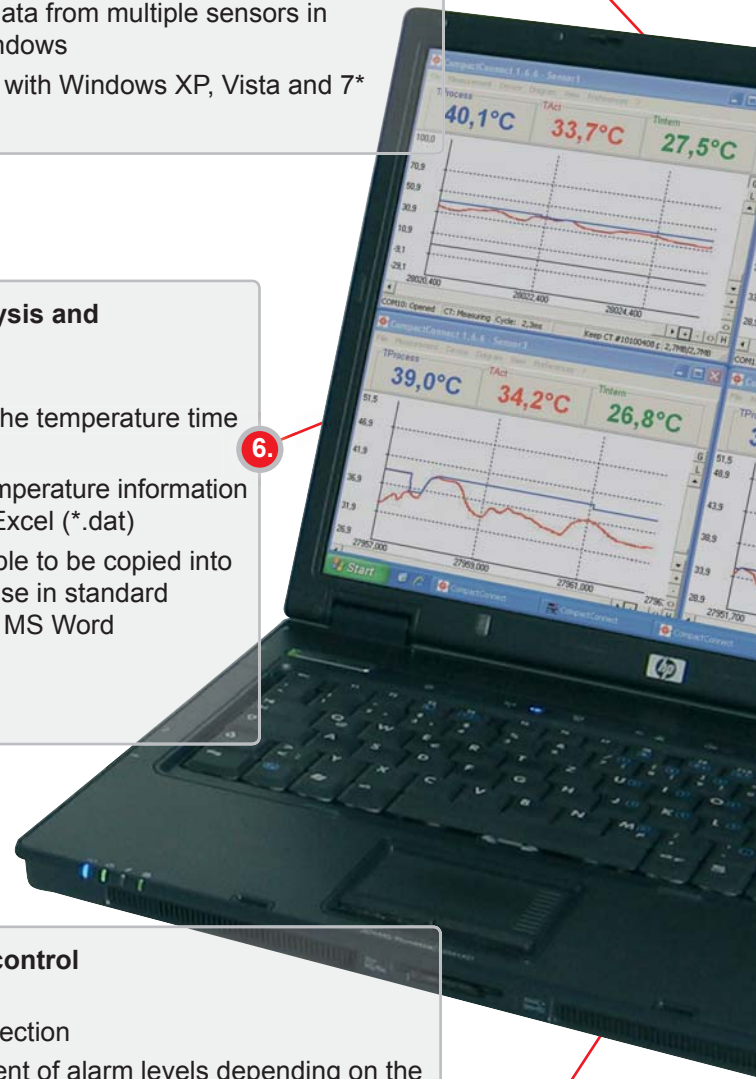

Time	TObj	TIn	TSur	TAct	T2C	T1C	ATTENUATION
00:00:00	29.3	27.8	0	29.3	0	0	0
00:00:05	29.3	27.8	0	29.3	0	0	0
00:00:10	29.3	27.8	0	29.3	0	0	0
00:00:15	29.3	27.8	0	29.3	0	0	0
00:00:20	29.3	27.8	0	29.3	0	0	0
00:00:25	29.3	27.8	0	29.3	0	0	0
00:00:30	29.3	27.8	0	29.3	0	0	0
00:00:35	29.3	27.8	0	29.3	0	0	0
00:00:40	29.3	27.8	0	29.3	0	0	0
00:00:45	29.3	27.8	0	29.3	0	0	0
00:00:50	29.3	27.8	0	29.3	0	0	0
00:00:55	29.3	27.8	0	29.3	0	0	0
00:01:00	29.3	27.8	0	29.3	0	0	0
00:01:05	29.3	27.8	0	29.3	0	0	0
00:01:10	29.3	27.8	0	29.3	0	0	0
00:01:15	29.3	27.8	0	29.3	0	0	0
00:01:20	29.3	27.8	0	29.3	0	0	0
00:01:25	29.3	27.8	0	29.3	0	0	0
00:01:30	29.3	27.8	0	29.3	0	0	0
00:01:35	29.3	27.8	0	29.3	0	0	0
00:01:40	29.3	27.8	0	29.3	0	0	0
00:01:45	29.3	27.8	0	29.3	0	0	0
00:01:50	29.3	27.8	0	29.3	0	0	0
00:01:55	29.3	27.8	0	29.3	0	0	0
00:02:00	29.3	27.8	0	29.3	0	0	0

### Temperature data analysis and documentation

- Detailed analysis of the temperature time diagram (zoom)
- Data storage of all temperature information for further work with Excel (\*.dat)
- Diagram window is able to be copied into clipboard for further use in standard programmes such as MS Word

6.



### Automatic process control

- Triggered data collection
- Individual adjustment of alarm levels depending on the process
- Definition of different analog and digital signal outputs (depending on interface option)
- optris CT LT / optris CTlaser LT: Entry of up to eight different emissivities for various materials with accordant alarm levels

5.



## Customer specific software adjustments

- Various language options including translation tool
- Temperature display in °C or °F
- Adjustment of layout
- Loading and saving of measurement parameter setups for individual applications
- Start of different software instances for display of multiple sensors
- Locking of programme keys at CT electronic

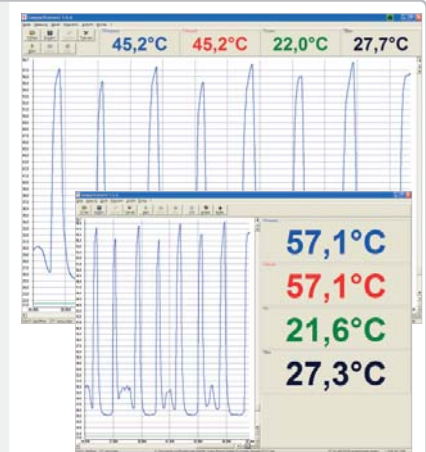

2.

## Complete device parameterization

- Setup of all measurement parameters of the sensor (emissivity, offset correction, alarm)
- Possibility of compensating background temperature
- Measurement simulation during device installation via output of sensor without actual measurement of surface temperature
- Automatic identification of unknown emissivity at known object temperature

3.

## Temperature display and recording

- Display of temperature merits within temperature time diagram as well as digital display
- Real time display of temperature data and parallel conversion (average, minimum and maximum merit)
- Automatic or manual adjustment of diagram scales for ideal merit display
- Data recording for future detailed analysis and documentation

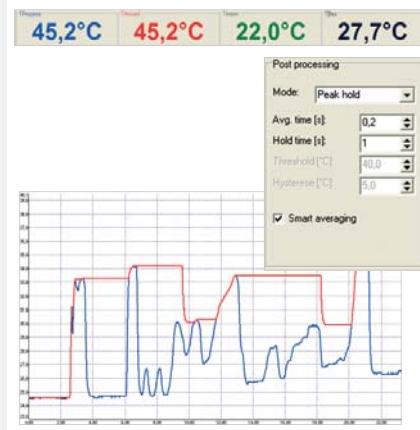

4.

\*Windows is a registered trademark of Microsoft Corporation.

### Analog Outputs

The optris CT devices of the compact and high performance series consists of an **electronic box**. The **analog interfaces** are connected to the box via connecting braces. One of the options, mV, mA or thermocouple (TC), can be chosen from the software optris Compact Connect for configuration as output.

The **object temperature** as well as the **alarm** can be displayed via the analog interface. An additional alarm output is available using the **open-collector**.

Output signal	Range	Connection pin within box
Voltage	0 ... 5 V	OUT-mV/mA
Voltage	0 ... 10 V	OUT-mV/mA
Current	0 ... 20 mA	OUT-mV/mA
Current	4 ... 20 mA	OUT-mV/mA
Thermocouple	TC J	OUT-TC
Thermocouple	TC K	OUT-TC

Overview of the analog outputs of the electronic box.

### Functional Inputs

The three **functional inputs** of the box F1, F2 and F3 are programmed via the software optris Compact Connect. The inputs offer the following setup possibilities:

- F1 (digital): Trigger
- F2 (analog): Emissivity (external)
- F3 (analog): Background temperature compensation (external)
- F1-F3 (digital): Emissivity (external)

### Maximum Flexibility through Digital, Exchangeable Interface Modules

The electronic boxes, included with the devices, can optionally be supplied with a USB-, RS232-, RS485-, Relay-, Profibus DP-, CAN-Bus- or Ethernet interface. If required, a quick and simple exchange of the **digital interface circuit board** is possible.

The adequate circuit board will then be placed into the intended area at the electronic box and the interface cable will be connected with the circuit board via the pre-assembled connecting brace.

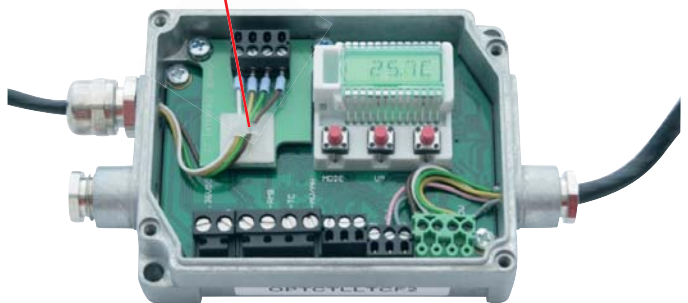

Pluggable, digital interface modules for maximal flexibility; simple to install via standard modules.

### Size of the Electronic Box

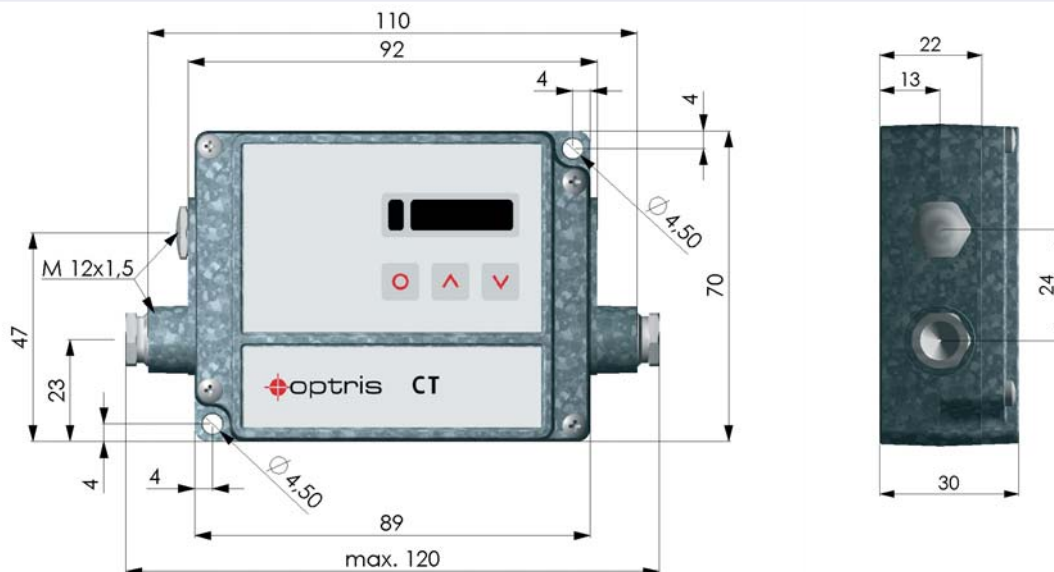

Dimensions in mm

## Intelligent Alarm Display

Oversteppings or undercutting of thresholds can be displayed via the alarm options at the electronic box through **changing colors at the LCD display**.

The **visual alarm** can additionally be setup to the configured alarm output of the box or to the optional relay interface.

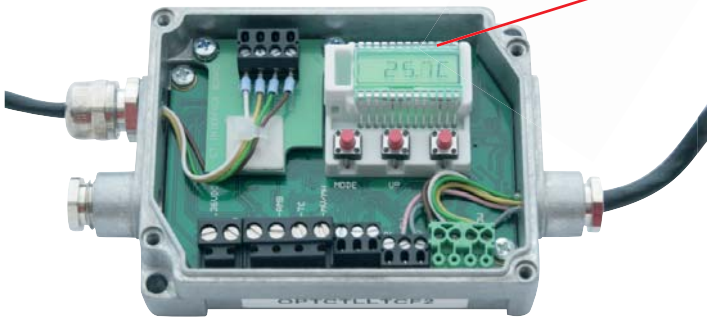

*Green display:*  
Temperature within limit of tolerance.



*Blue display:*  
Temperatur below threshold.



*Red display:*  
Temperature above threshold.



## Simple Exchange of Sensing Head, Cable or Electronic Box

The attached sensing head and the head cable at the electronic box are factory-made.

Various possibilities to exchange the **sensing heads, cables and electronic boxes** are available if process parameters are changing or in case of damage. Optris therefore offers its customers a **maximum of flexibility** with low exchange costs.



*Example 1: Compact series*



*Example 2: High performance series*

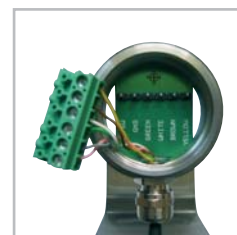

*Electronic box, cable, sensing head are exchangeable in various versions.*

Application Example: Simple Multiple Installation via Electronic Box (RS485)

The following display shows how multiple measurement devices can be combined with each other via the electronic box and the RS485 interface. It is possible to operate up to **32 sensors in one network** using the **RS485 mode**. In this example, the optris CSmicro LT measures a reference temperature to compensate the background temperature within the process which will be considered during the temperature calculation of the other measuring devices.

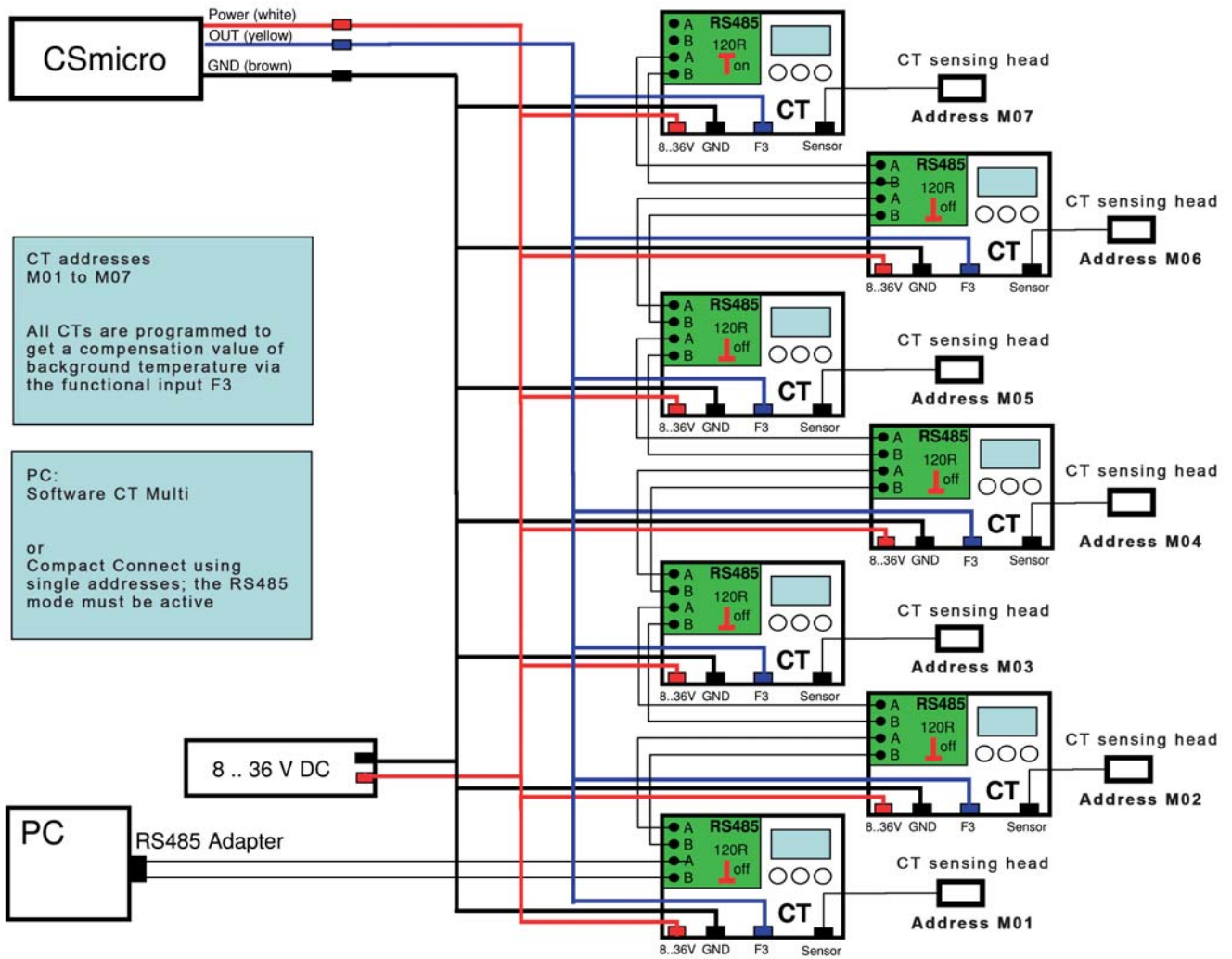

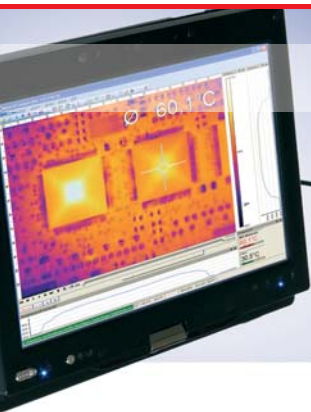

## INFRARED CAMERAS

Compact & Flexible  
Recording within Milliseconds  
Extensive Software Package



### Compact Infrared Camera with USB 2.0 Interface



The thermal imager optris PI is a fixed infrared camera with an **outstanding** state of the art **cost-performance-ratio**. The camera is connected to a PC with an **USB 2.0** and can immediately be used after connection. The corresponding software optris PI Connect displays the captured temperature data as a thermal image. The software also covers the remote control of the camera.

The infrared camera optris PI is based on a small uncooled bolometer (UFPA) with **160 x 120 pixel** and a pixel size of  $25\ \mu\text{m} \times 25\ \mu\text{m}$ . The camera delivers thermal images in **real time** with a frequency of **120 Hz**. Measurement results can be captured and stored as **snapshots or video sequences**. It is possible to detect smallest temperature differences at an object due to the very good thermal sensitivity (NETD 0.08 K with  $23^\circ$  FOV) of the camera.

In a ready to use mode, the camera's weight is only **250 gram**, including the lens and cable. Additionally it is one of the **smallest thermal imager** in the world (dimensions: 45 mm x 45 mm x 62 mm). In combination with a tablet PC the camera is used as a mobile solution for preventive maintenance or construction thermography. The optris PI therefore covers the existing gap between portable infrared snapshot cameras and pure fixed devices.

### Searching for Critical Areas



The optris PI thermal imager has been developed to thermally determine objects and automatically detect hot or cold spots.

Typical applications are:

- **Research and Development (R&D)**
- **Test stations (T&M)**
- **Process automation**
- **Portable measurement tasks**

The camera is ideal to be used in **cramped areas**, such as engine construction or within test stations, due to the very small size of the camera.

Further typical applications are:

- Thermoforming of plastic foils
- Test of breaks within the automotive industry
- Quality control of circuit boards or solar modules
- Thermal monitoring of paper webs
- Control of heat development at medical products
- Hot spot – search on conveyer belts

### Adaptable Temperature Ranges



The optris PI presents thermal images covering a wide overall temperature range between **-20°C and 900°C**.

The **individual areas** from -20°C to 100°C, 0°C to 250°C and 150°C to 900°C can be selected individually depending on the application:

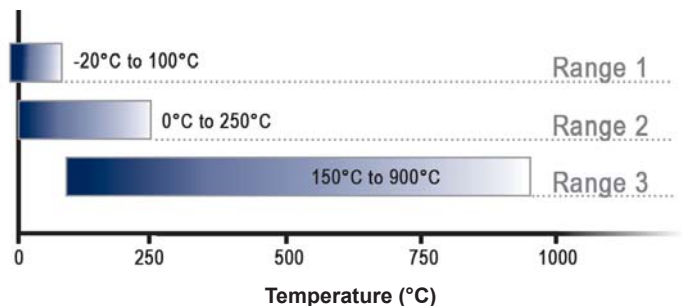

Temperature range of the infrared cameras.

Measurement of Smallest Objects in the Range of  $\mu\text{m}$

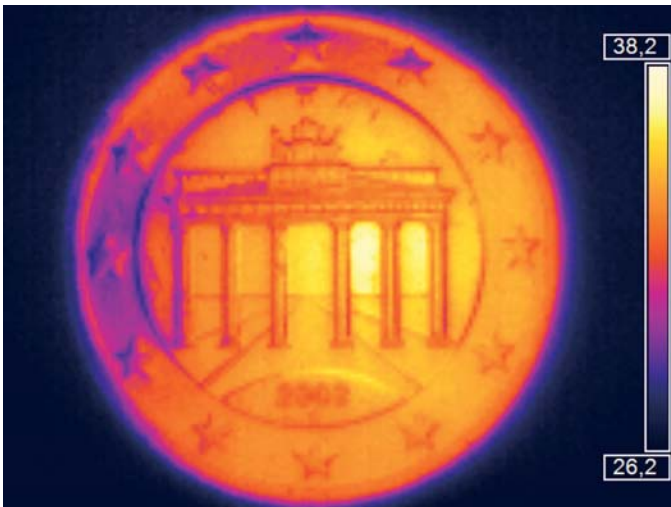

Impressive quality of the thermal image by smart rendering.

The variety of different lenses offers the possibility to precisely measure objects in **different distances**. We offer lenses for close and standard distances ( $48^\circ \times 37^\circ$  and  $23^\circ \times 17^\circ$ ) and a lens for great distances ( $6^\circ \times 5^\circ$ ).

The **standard package** of the camera includes one lens. The **thermal analysis package** includes all three lenses - so that customers can easily adjust the lens to the needs of their applications.

Different parameters are important if using infrared cameras. They display the connection between the distance of the measured object and the size of the pixel. When choosing a lens, the following data should be considered:

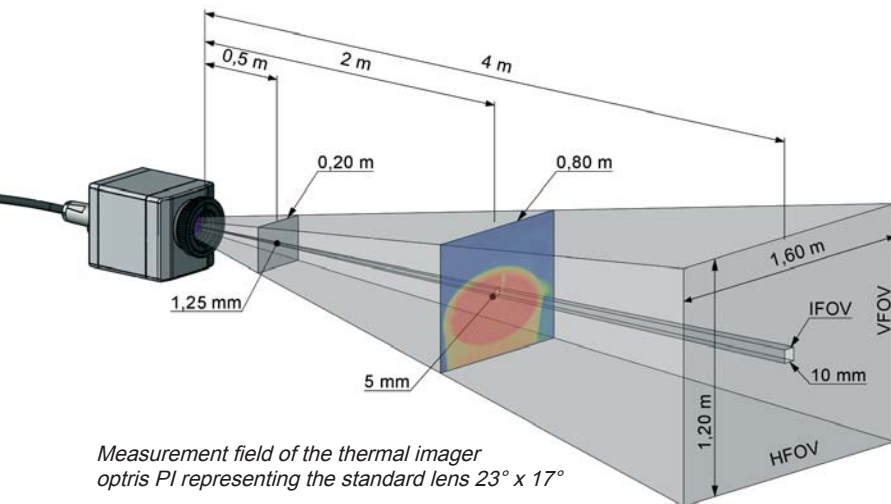

Measurement field of the thermal imager optris PI representing the standard lens  $23^\circ \times 17^\circ$

- **HFOV**: Horizontal enlargement of the total measuring field at object level
- **VFOV**: Vertical enlargement of the total measuring field at object level
- **IFOV**: Size of the single pixel at object level
- **MFOV**: Recommended, smallest measured object size of 3 x 3 pixel

Lens	Focal Length	Minimum Distance	Distance to the device under test [m]												
				0.02	0.1	0.2	0.3	0.5	1.2	2	4	6	10	30	100
23° x 17° Standard lens	10 mm	0.02 m*	HFOV [m]	0.008	0.04	0.08	0.12	0.20	0.48	0.80	1.60	2.4	4.0	12.0	40.0
			VFOV [m]	0.006	0.03	0.06	0.09	0.15	0.36	0.60	1.20	1.8	3.0	9.0	30.0
			IFOV [mm]	0.050	0.25	0.50	0.75	1.25	3.00	5.00	10.00	15.0	25.0	75.0	250.0
6° x 5° Tele lens	35.5 mm	0.5 m	HFOV [m]					0.06	0.14	0.23	0.45	0.7	1.1	3.4	11.3
			VFOV [m]					0.04	0.10	0.17	0.34	0.5	0.8	2.5	8.5
			IFOV [mm]					0.35	0.85	1.41	2.82	4.2	7.0	21.1	70.4
48° x 37° Wide angle lens	4.5 mm	0.02 m*	HFOV [m]	0.018	0.09	0.18	0.27	0.44	1.07	1.78	3.56	5.3	8.9	26.7	88.9
			VFOV [m]	0.013	0.07	0.13	0.20	0.33	0.80	1.33	2.67	4.0	6.7	20.0	66.7
			IFOV [mm]	0.111	0.56	1.11	1.67	2.78	6.67	11.11	22.22	33.3	55.6	166.7	555.6

Table with examples showing what spot sizes and pixel sizes will be reached in what distance. Three different lenses are available for the camera. \*Note: The accuracy of measurement can be outside of the specifications for distances below 0.2 m.

## Measuring Temperature in Milliseconds



The optris PI displays the temperature distribution at a surface as well as the accurate temperatures within an **8 millisecond interval**.

### Example: Adding milk into a coffee cup...

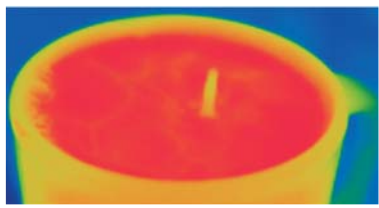

*...at first, the drop falls down...*

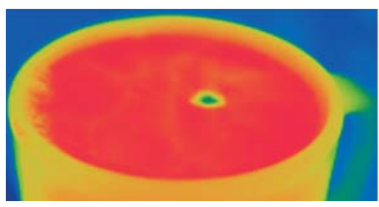

*...dives into the coffee cup...*

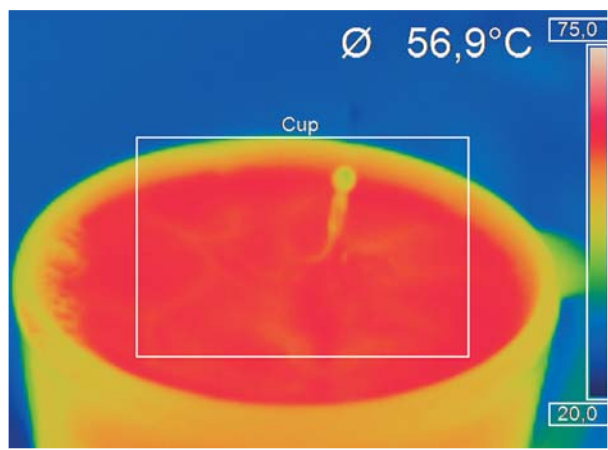

*...and appears again as a drop.*



## Industrial Protection and Cooling



The optris PI thermal imager comes with a housing of the **protection class IP 67 (NEMA-4)** and can be installed in surroundings with temperatures up to 50°C. The optional cooling housing allows the installation of the camera in **rough, industrial surroundings**. An application can take place at up to 100°C in connection with air cooling (like the VORTEX cooler). The air cooling apparatus is concurrently the **air purge collar** which protects the lens from dirt. The optris PI can be used for ambient temperatures of up to **240°C** in combination with the **water cooling system**.



*Cooling housing with air and water cooling options for the use within up to 240°C ambient temperature.*

## Process Integration beyond USB 2.0



Possibilities for network integration and modern interface concepts support the customers to use the camera in automated systems:

### USB cable extensions

- USB cable extension up to 20 m
- USB over Ethernet: Remote control of camera up to 100 m distance
- USB over Fiber: Remote control of camera up to 10 km distance

### Process interface (PIF) at camera

- Analog output: 0 to 10 V signal for data transfer such as temperatures
- Analog input: 0 to 10 V signal to receive datas such as reference temperatures of external infrared thermometers
- Digital input: Low and high level for reception of data such as trigger signal for data recording

### Software interface

- Interprocess communication (IPC): Dynamic link library (DLL) to embed datas such as temperatures of other applications
- Comport: Computer port to sent datas

Software optris PI Connect (Picture Example: String Soldering of Solar Cells)



Extensive infrared camera software

- No additional costs
- No restrictions in licencing
- Modern software with intuitive user interface
- Remote control of camera via software
- Display of multiple camera images in different windows
- Compatible with Windows XP, Vista and 7 as well as LabVIEW\*

1.

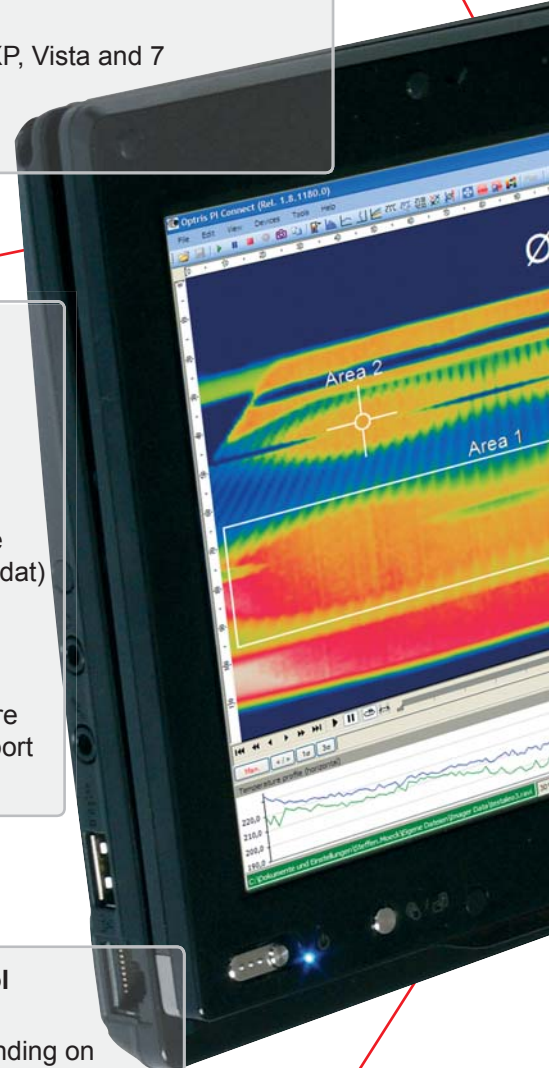

6.

Temperature data analysis and documentation

- Triggered data collection
- Radiometric video sequences (\*.ravi)
- Radiometric snapshots (\*.jpg, \*.tiff)
- Text files including complete temperature information for analysis in Excel (\*.csv, \*.dat)
- Data with color information for standard programmes such as Photoshop or Windows Media Player (\*.avi, \*.jpg, \*.tiff)
- Data transfer in real time to other software programmes via LabVIEW, DLL or Comport interfaces

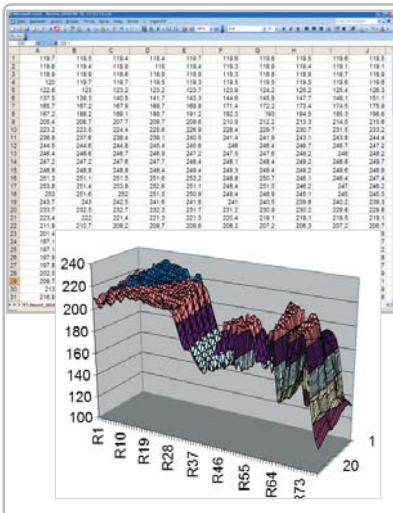

Automatic process and quality control

- Individual setup of alarm levels depending on the process
- BI-SPECTRAL process monitoring (IR and VIS) for easy orientation at point of measurement
- Definition of visual or acoustic alarms and analog data output via the process interface
- Analog and digital signal input (process parameter)
- External communication of software via Comports, DLL and LabVIEW driver
- Adjustment of thermal image via reference values

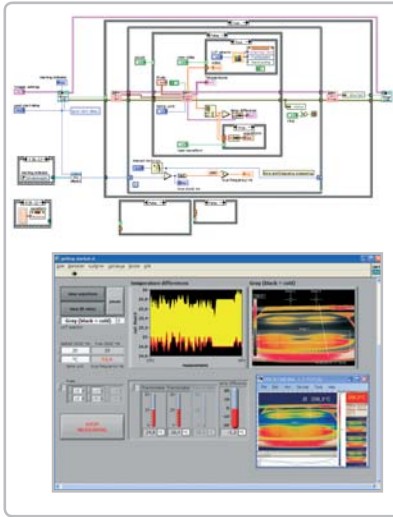

5.



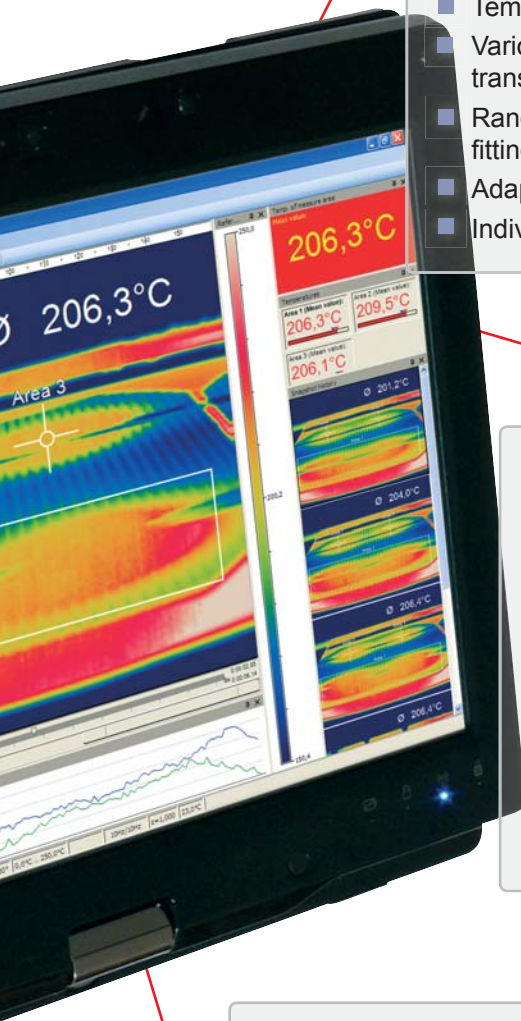

**2. High level of individualization for customer specific display**

- Different layout options for an individual setup (arrangement of windows, toolbar)
- Temperature display in °C or °F
- Various language options including a translation tool
- Range of individual measurement parameter fitting for each application
- Adaption of thermal image (mirror, rotate)
- Individual start options (full screen, hidden, etc.)

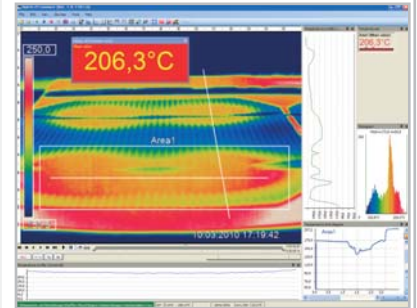

**3.**

**Video recording and snapshot function (IR or BI-SPECTRAL)**

- Recording of video sequences and detailed frames for further analysis or documentation
- BI-SPECTRAL video analysis (IR and VIS) in order to highlight critical temperatures
- Adjustment of recording frequency to reduce data volume
- Display of snapshot history for immediate analysis

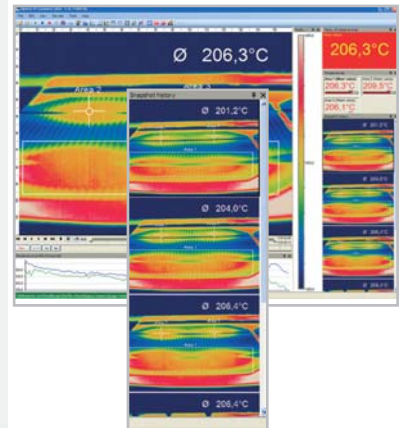

**Extensive online and offline data analysis**

- Analysis supported by measurement fields, hot and cold spot searching, image substraction
- Real time temperature information within main window as digital or graphic display (line profile, temperature time diagram)
- Slow motion repeat of radiometric files and analysis without camera being connected
- Editing of sequences such as cutting and saving of individual images
- Various color palettes to highlight thermal contrasts

**4.**

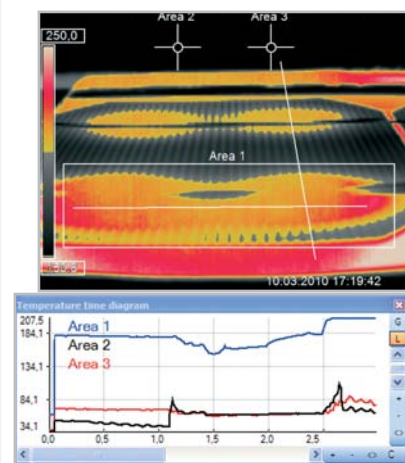

\*Windows is a registered trademark of Microsoft Corporation. LabVIEW is a registered trademark of National Instruments.

### Special Function of the optris PI Connect: Linescanner Mode

The optris PI Connect software comes with a linescanner function. The linescanner mode is generally used for **processes with moving objects** under test, such as measurement of rotary kilns or measurement of great lots at conveyor belts (batch process). Overview of the advantages:

1. Simple monitoring of process with limited optical access
2. Indirect visualization of heat distribution within ovens via camera installation at the oven exit
3. Extension of number of pixel from 160 pixel up to 200 pixel through use of picture diagonal
4. 120 Hz data recording of unlimited lines which in turn can produce thermal images of any resolution
5. 60° FOV as a line for detailed process analysis such as at wide conveyor belts

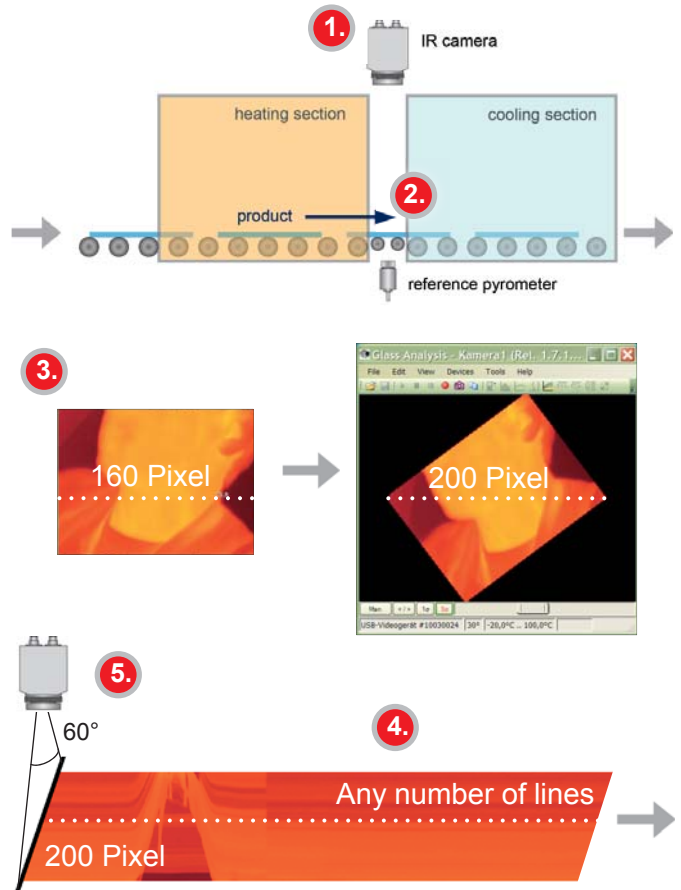

Application example:  
Rotary kiln within the  
chemical industry.

### Special Function of the optris PI Connect: BI-SPECTRAL technology

With the help of BI-SPECTRAL technology, a **visual image (VIS)** can be combined with a thermal image (IR). Both images can be **captured time synchronously**:

**Monitoring modus:**

Easy orientation at point of measurement

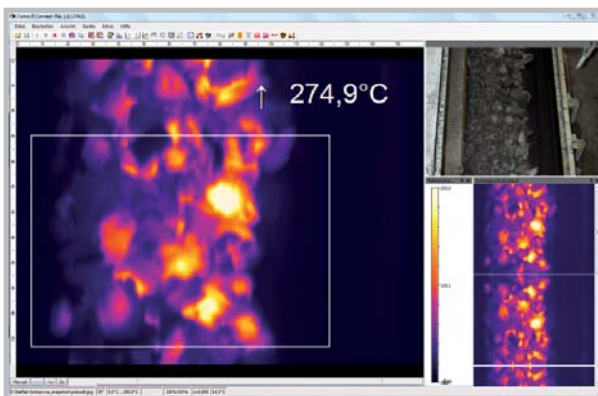

**Cross-fading modus:**

Highlighting of critical temperatures

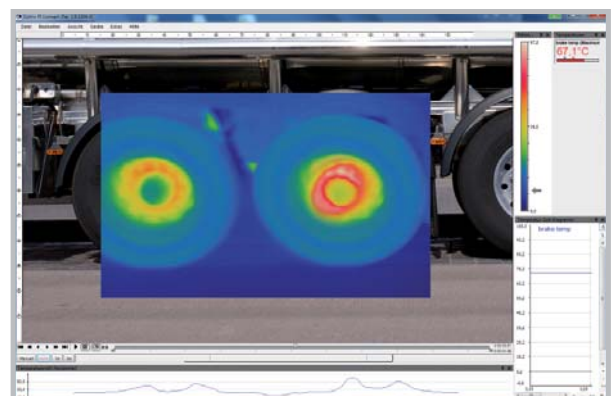

## Technical data of the infrared cameras

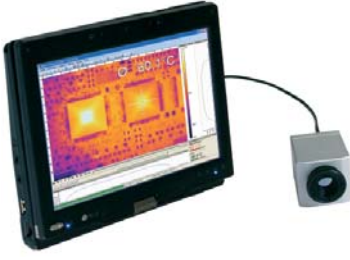
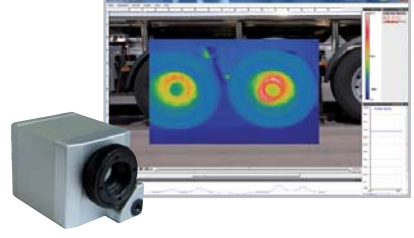
Basis model	PI160	PI200
Type	IR	BI-SPECTRAL
		
Classification	USB camera incl. 1 lens, USB cable (1 m), table tripod, PIF cable incl. terminal block (1 m), software package optris PI Connect, aluminium case	USB camera with 1 lens and BI-SPECTRAL technology, USB cable (1 m), table tripod, PIF cable incl. terminal block (1 m), software package optris PI Connect, aluminium case
Detector	FPA, uncooled (25 µm x 25 µm)	FPA, uncooled (25 µm x 25 µm)
Optical resolution	160 x 120 pixel	160 x 120 pixel
Spectral range	7,5 - 13 µm	7,5 - 13 µm
Temperature ranges	-20°C...100°C, 0°C...250°C, 150°C...900°C	-20°C...100°C, 0°C...250°C, 150°C...900°C
Frame rate	120 Hz	96 Hz
Optics (FOV)	23° x 17° FOV / f = 10 mm <u>or</u> 6° x 5° FOV / f = 35,5 mm <u>or</u> 48° x 37° FOV / f = 4,5 mm	23° x 17° FOV / f = 10 mm <u>or</u> 6° x 5° FOV / f = 35,5 mm <u>or</u> 48° x 37° FOV / f = 4,5 mm
Thermal sensitivity (NETD)	0.08 K with 23° x 17° FOV / F = 0,7 0.3 K with 6° x 5° FOV / F = 1,6 0.1 K with 48° x 37° FOV / F = 1	0.08 K with 23° x 17° FOV / F = 0,7 0.3 K with 6° x 5° FOV / F = 1,6 0.1 K with 48° x 37° FOV / F = 1
Option for visual camera (only for BI-SPECTRAL camera)		Optical resolution: 640 x 480 Pixel Frame rate: 32 Hz Optics (FOV): 54° x 40°
Accuracy	±2°C or ±2%	±2°C or ±2%
PC interface	USB 2.0	USB 2.0
Process interface (PIF)	0 - 10 V input, digital input, 0 - 10 V output	0 - 10 V input, digital input, 0 - 10 V output
Ambient temperature (T <sub>Umg</sub> )	0°C...50°C	0°C...50°C
Storage temperature	-40°C...70°C	-40°C...70°C
Relative humidity	20 - 80%, non condensing	20 - 80%, non condensing
Enclosure (size / rating)	45 mm x 45 mm x 62 mm / IP 67	45 mm x 45 mm x 62 mm / IP 67
Weight	195 g, incl. lens	215 g, incl. lens
Shock / vibration	25G, IEC 68-2-29 / 2G, IEC 68-2-6	25G, IEC 68-2-29 / 2G, IEC 68-2-6
Tripod mount	1/4-20 UNC	1/4-20 UNC
Power supply	USB powered	USB powered

### The optris PI thermal imager as Thermal Analysis Package

- Infrared camera optris PI160 or PI200
- 3 lenses including calibration certificate
- USB cable (1 m and 10 m)
- Table tripod (20 - 63 cm)
- PIF cable with terminal block (1 m)
- Software package optris PI Connect
- Aluminum case

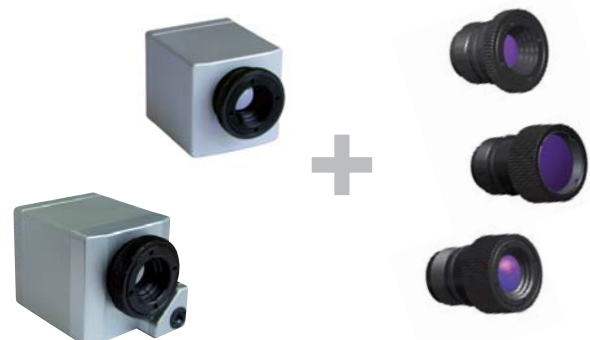

## Accessories



Cooling housing  
(not for BI-SPECTRAL  
camera version)



Mounting angle,  
for cooling housing,  
adjustable in two axes



Mounting flange,  
for protection pipe or  
cooling housing

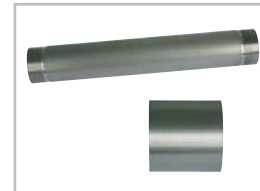

Protection pipe and  
pipe adapter for cooling  
housing



High temperature USB  
cable

## Application Example: Acceptance Test of Circuit Boards

More and more manufacturer of electrical devices and conductor boards use non-contact temperature measurement due to the continuous growing demand of efficiency.

By using the optris PI thermal imager a detailed real time analysis of **thermal behavior** of circuit boards is made possible within the area of research and development but also within batch production. The 120 Hz real time monitoring visualizes very short thermal incidents at the electronic devices.

The thermal behavior of smallest objects starting from a size of 50  $\mu\text{m}$  can be displayed by the camera (e.g. of **SMD component during acceptance tests**). The elements are accurately measurable for their temperature starting from a size of 0.5 mm.

Besides the recording function, the software offers an additional snapshot function to record and document. The adjustment of the camera software to **industrial PLCs** is standard.

### Advantages of the optris PI thermal imager:

- Small imager for simple fitting in test stations
- Capturing of fast changes in temperature through 120 Hz frequency
- Measurement of smallest details from 50  $\mu\text{m}$  through high optical resolution
- Extensive, later software analysis for process optimization
- Documentation of triggered video sequences and snapshot function

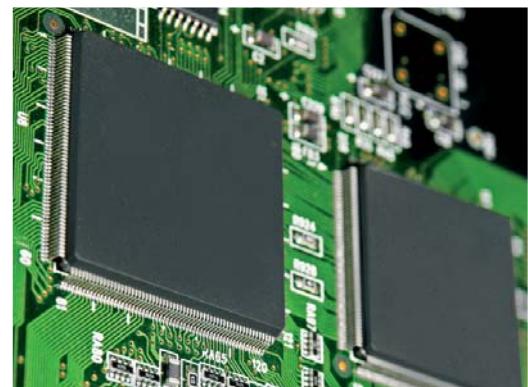

*Continuous quality control of circuit boards at test stations*

## PORTABLE THERMOMETERS

Portable Measurement Tasks

Internal Data Storage

Analysis via USB

### Portable Thermometers for Demanding Handheld Applications



The Optris portable thermometers are characterized by combining a **modern industrial design** with outstanding technical parameters. The **high-class precision lenses** assure the precise measurement of objects in short or long distances. The portable thermometer optris LS LT consists of an one of a kind, switchable lens. This means that smallest objects can be measured in a close-up range as well as in mean distances.

The portable thermometers of the optris MS series consist of a single point laser to mark the middle of the measuring field.

All additional devices to this series feature an **innovative laser sighting concept**. This means that the laser are following the infrared optical path to mark the accurate size and spot of the measuring field at every distance. For the portable thermometer optris P20 this is carried out by a double laser sighting whilst the optris LS LT consists of **worldwide patented cross hair laser sighting system**.

All portable thermometers come with a **LCD color alarm**. This alarm offers to visualize an under-run or over-run of a defined temperature barrier with varying colors of the display background. The display of the optris LS LT can also flip according to the beholders position (integrated absolute position transducer).

The complete portable thermometer series consists of an **USB interface**. Temperature gradation can be displayed and recorded at a PC in connection with the optris Connect software.

### Occasionally Measurements



All Optris portable thermometes are suitable for measurement tasks where sporadic temperature monitoring is sufficient. Application examples are:

#### Non-metal surfaces (LT)

- MS series: Mechanical and electrical maintenance
- LS LT: Matted catalyzer at engine test benches
- LS LT: Electronic development at R&D
- P20 LT: Testing of outside wall of melting tanks

#### Metal surfaces (2M; 1M)

- P20 2M: Rolling of iron sheets
- P20 1M: Steel slab temperature

### Suitable for Every Temperature



The portable thermometers cover a wide temperature range. Some devices are also suitable for the measurement of high temperatures at metal surfaces.

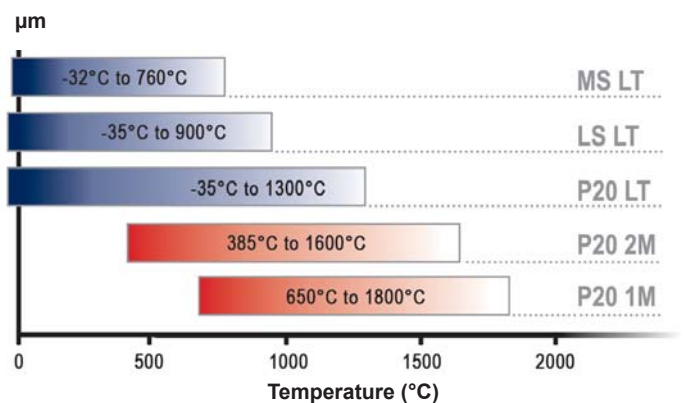

Temperature range of the portable thermometers across the wavelengths.

## Best Optics for Portable Thermometers



The optics of the portable thermometers are designed for mean distances. The **optris LS LT** comes with an **unique, switchable lens** which means that smaller objects can precisely be measured in a close-up range.

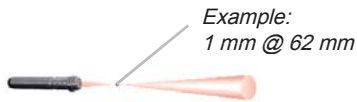

Close lens (CF, close focus): Measurement of smallest objects under test close to the sensor (only optris LS LT)



Standard lens (SF, standard focus): Measurement of smallest objects under test in mean distances.

## Accessories

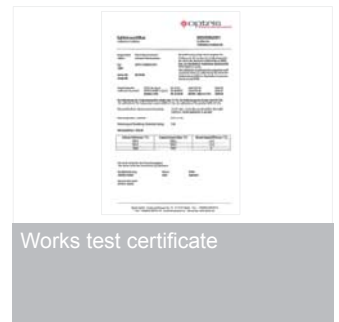
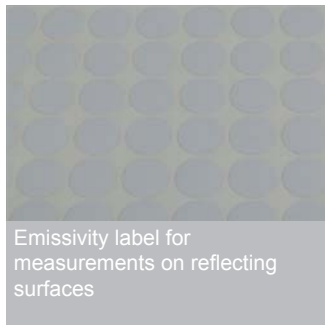

## Software optris Connect

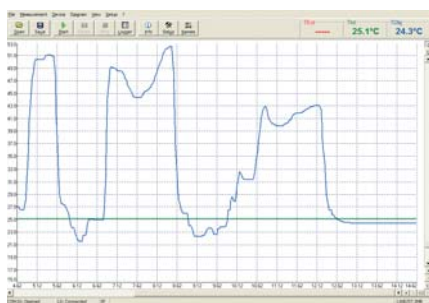

### General

- Connection of all portable thermometer via an USB interface
- Various language options including translation tool
- Temperature display in °C or °F
- Compatible with Windows XP, Vista and 7
- Simple setup of picture based temperature reports

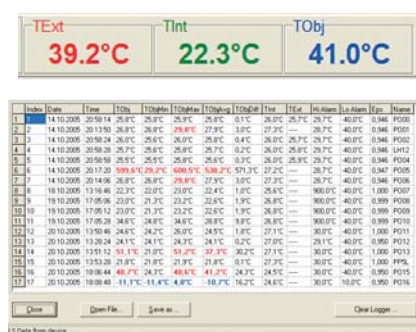

### Display and analysis of temperatures

- Display of temperature data within temperature time diagram or via digital display
- Automatic or manual adjustment of diagram scale
- Data recording for a later detailed analysis or documentation
- File storage including complete temperature information for analysis in Excel (\*.dat)
- Download of logger data in clearly arranged tables (display Hi-Alarm in red, Lo-Alarm in blue)

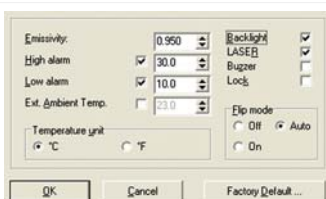

### Changing of device setup

- Setup of emissivity for measurement of different surfaces
- Possibility of external background temperature compensation (only optris LS LT)

## Product Overview of Portable Thermometers

Base Model	LS	P20	P20	MS	MSPlus	MSPro
Type		LT	1M / 2M	LT	LT	LT
						
Detector	Thermopile	Thermopile	Si / InGaAs	Thermopile	Thermopile	Thermopile
Spectral range	8-14 $\mu\text{m}$	8-14 $\mu\text{m}$	1.0 / 1.6 $\mu\text{m}$	8-14 $\mu\text{m}$	8-14 $\mu\text{m}$	8-14 $\mu\text{m}$
Temperature ranges	-35°C...900°C	0°C...1300°C	650°C...1800°C 385°C...1600°C	-32°C...420°C	-32°C...530°C	-32°C...760°C
Temperature resolution	0.1°C	1°C	1°C	0.2°C	0.1°C	0.1°C
Optical resolution	75:1	120:1	300:1	20:1	20:1	40:1
Switchable optics	■	-	-	-	-	-
Smallest spot (CF optics)	1 mm @ 62 mm	-	-	-	-	-
Smallest spot (SF optics)	16 mm @ 1200 mm	100 mm @ 12 m	12 mm @ 3.6 m	13 mm bis 140 mm	13 mm bis 140 mm	13 mm bis 260 mm
Sighting	Cross hair laser	Double laser	Double laser	Laser	Laser	Laser
Response time (90%)	150 ms	300 ms	100 ms	300 ms	300 ms	300 ms
Accuracy	$\pm 0.75^\circ\text{C}$ or $\pm 0.75\%$	$\pm 2^\circ\text{C}$ or $\pm 1\%$	$\pm (0.3\% T_{\text{Meas}} + 2^\circ\text{C})$	$\pm 1^\circ\text{C}$ or $\pm 1\%$	$\pm 1^\circ\text{C}$ or $\pm 1\%$	$\pm 1^\circ\text{C}$ or $\pm 1\%$
PC interface	USB	USB	USB	USB	USB	USB
Software	■	■	■	■	■	■
Probe connection (t/c)	■	-	-	-	■	■
T <sub>Amb</sub> min. / max.	0°C / 50°C	0°C / 50°C	0°C / 50°C	0°C / 50°C	0°C / 50°C	0°C / 50°C
Display MAX / MIN / HOLD	■	■	■	■	■	■
HIGH / LOW alarm	■	■	■	-	■	■
Data logger / capacity	■ / 100	■ / 2000	■ / 2000	-	-	■ / 20
Emissivity	0.100...1.100	0.100...1.100	0.100...1.100	0.95 fixed	0.100...1.100	0.100...1.100

## Application Examples

### Preventive electrical maintenance



Almost every current asset which is supported by energy turns hot before a breakdown. Temperature monitoring can best be provided with an optris LS LT in line with preventive electronic maintenance.

### Defect analysis for air conditioning technology



The optris MSPro LT saves time and money during maintenance of heating systems, ventilators and air conditioning. Error sources, such as leaks or clogged filters, can be localized within short times and unscheduled cutoffs can be avoided.

### Fast diagnosis at car garages



Accurate measurement results are demands of every master mechanic to fastly detect and repair troubles at engines, catalyzers or breaking systems. Therefore the optris MS LT is an important measurement device at garages.

### Hot deforming of metals



Close temperature limits need to be met during hot deforming processes of metal to fulfill the quality demands of the raw materials. The optris P20 2M can be used for sporadic monitoring in forging and bending processes.



Optris GmbH  
Ferdinand-Buisson-Str. 14 • 13127 Berlin • Germany  
Tel.: +49 30 500 197-0 • Fax: +49 30 500 197-10  
Email: sales@optris.com • Internet: www.optris.com

